

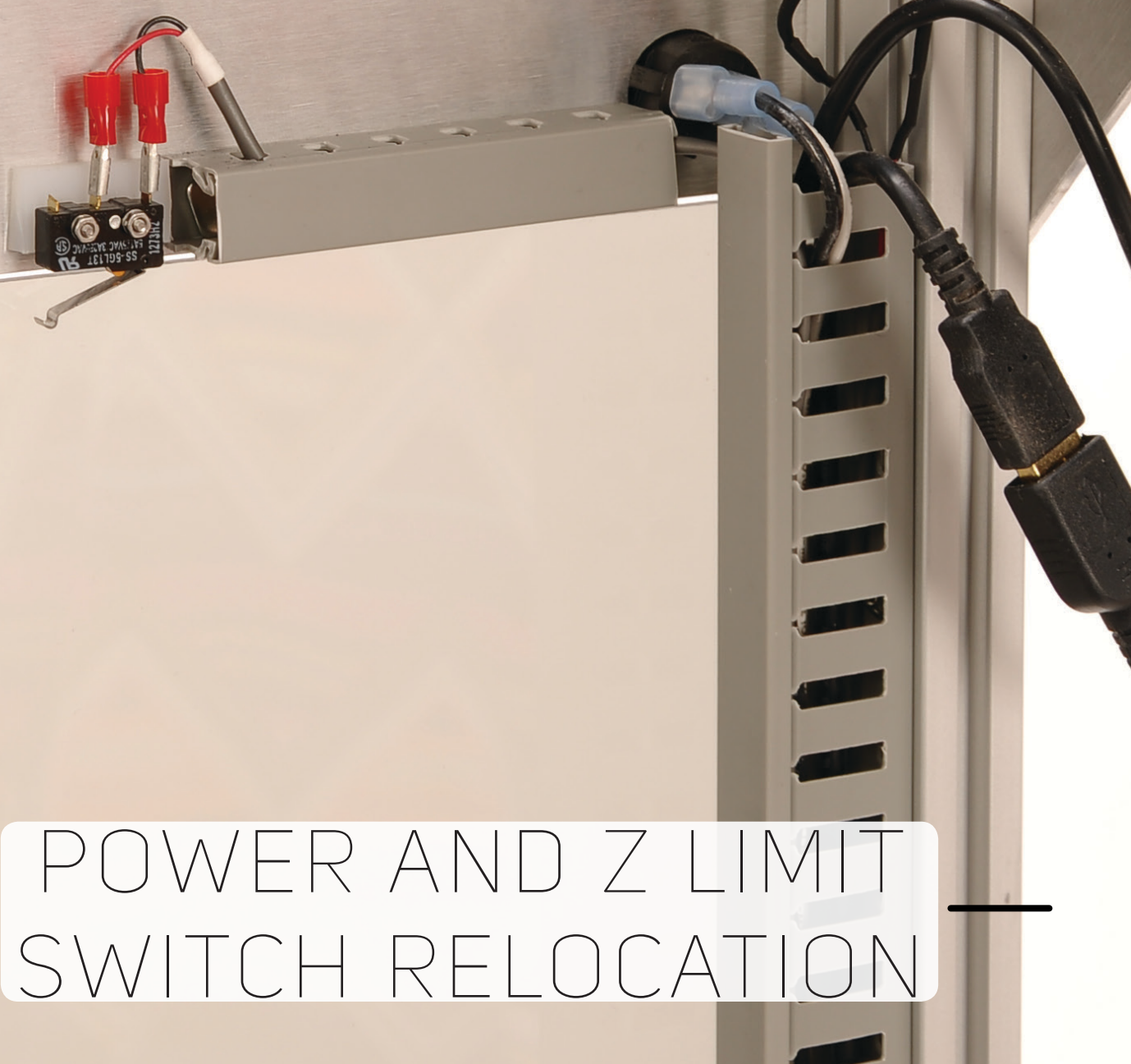

GIGABOT[®]

THINK BIG,
PRINT HUGE



POWER AND Z LIMIT
SWITCH RELOCATION



REV. OCTOBER 2015

INTRODUCTION

THANK YOU FOR PURCHASING THE POWER AND Z LIMIT SWITCH RETROFIT KIT FROM re:3D Inc.®!

This upgrade will let you the power switch and Z limit switch on your current Gigabot®. You will find that this is especially helpful for making easy adjustments on the Z end stop screw if you have side panels installed on your machine. Also, the new power switch location will make it much more convenient to shut off your Gigabot.

REFERENCES & HELPFUL DOCUMENTS :

Some external resources may be helpful during the assembly process. For example, knowing the correct names for different parts on the Gigabot®, or proper use of certain tools. Resources that we thought may be helpful have been linked to at the end of this guide.

VIDEO INSTRUCTIONS :

If you prefer a video guide, please search for “re3D Tech” on YouTube and find our “Power and Z Limit Switch Relocation” video.

LEGALESE

READ INSTRUCTIONS : All the safety and operating instructions should be read before the printer is operated.

RETAIN INSTRUCTIONS : The safety and operating instructions should be retained for future reference.

HEED WARNINGS : All warnings on the product and in the operating instructions should be adhered to.

FOLLOW INSTRUCTIONS : All operating and use instructions should be followed.

CLEANING : Unplug this product from the wall outlet before cleaning. Do not use liquid or aerosol cleaners.

ATTACHMENTS : Do not use attachments or enhancements not recommended by the product manufacturer as they may cause hazards.

WATER AND MOISTURE : Do not use Gigabot near water - for example, near a bath tub, wash bowl, kitchen sink, or laundry tub, in a wet basement, or near a swimming pool, and the like.

PLACEMENT : Do not place this product on an unstable cart, stand, tripod, bracket, or table. The product may fall, causing serious injury to a child or adult, and serious damage to the product. Use only with a cart, stand, tripod, bracket, or table recommended by the manufacturer, or sold with the product. Any mounting of the product should follow the manufacturer's instructions, and should use a mounting accessory recommended by the manufacturer.

VENTILATION : Slots and openings in the cabinet are provided for ventilation and to ensure reliable operation of the product and to protect it from overheating, and these openings must not be blocked or covered. The openings should never be blocked by placing the product on a bed, sofa, rug, or other similar surface. This product should not be placed in a built-in installation such as a bookcase or rack unless proper ventilation is provided or the manufacturer's instructions have been adhered to.

POWER SOURCES : This product should be operated only from the type of power source indicated on the marking label. If you are not sure of the type of power supply to your home consult your appliance dealer or local power company. For products intended to operate from battery power, or other sources, refer to the operating instructions.

GROUNDING OR POLARIZATION : This product may be equipped with either a polarized 2-wire AC line plug (a plug having one blade wider than the other) or a 3-wire grounding type plug, a plug having a third (grounding) pin. The 2-wire polarized plug will outlet, try reversing the plug. If the plug still fails to fit, contact your electrician to replace your obsolete outlet. Do not defeat the safety purpose of the polarized plug. The 3-wire grounding type plug will fit into a grounding type power outlet. This is a safety feature. If you are unable to insert the plug into the outlet, contact your electrician to replace your obsolete outlet. Do not defeat the safety purpose of the grounding type plug.

POWER-CORD PROTECTION : Power-supply cords should be routed so that they are not likely to be walked on or pinched by items placed upon or against them, paying particular attention to cords at plugs, convenience receptacles, and the point where they exit from the product.

LIGHTNING : For added protection for this product during a lightning storm, or when it is left unattended and unused for long periods of time, unplug it from the wall outlet and disconnect the antenna or cable system. This will prevent damage to the product due to lightning and power-line surges.

OVERLOADING : Do not overload wall outlets, extension cords, or integral convenience receptacles as this can result in a risk of fire or electric shock. A product and cart combination should be moved with care. Quick stops, excessive force, and uneven surfaces may cause the product and cart combination to overturn.

OBJECT AND LIQUID ENTRY : Never push objects of any kind into this product through openings as they may touch dangerous voltage points or short-out parts that could result in a fire or electric shock. Never spill liquid of any kind on the product.

TABLE OF CONTENTS

OVERVIEW	1
LEGEND	2
BEFORE YOU BUILD	4
BUILD GUIDE	6
BILL OF MATERIALS	6
TOOLS YOU'LL NEED	7
A : REMOVAL AND REPLACEMENT	8
B : DRILLING EXTRA HOLES	13
C : MOUNTING AND PLACEMENT	23
D : WIRING	32



OVERVIEW

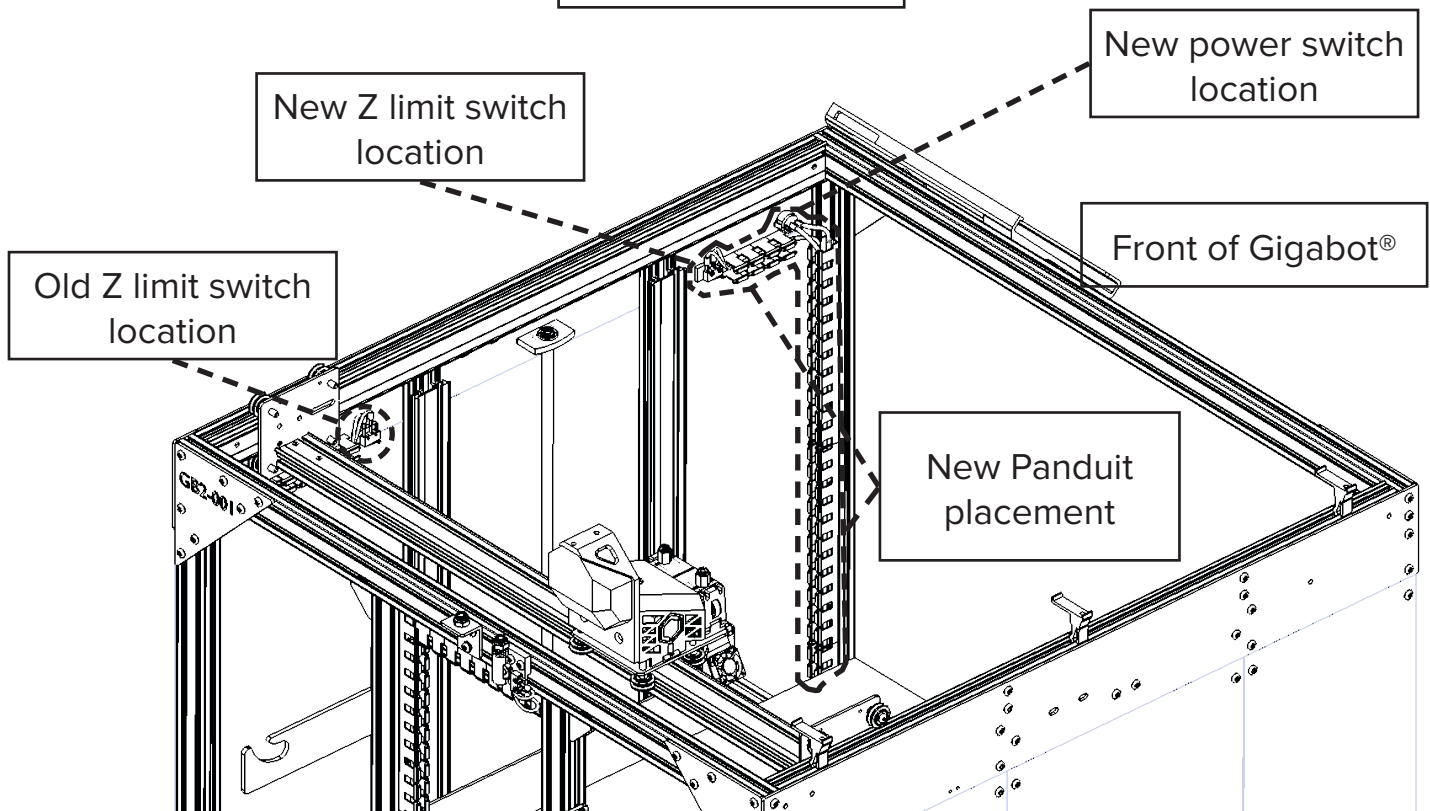
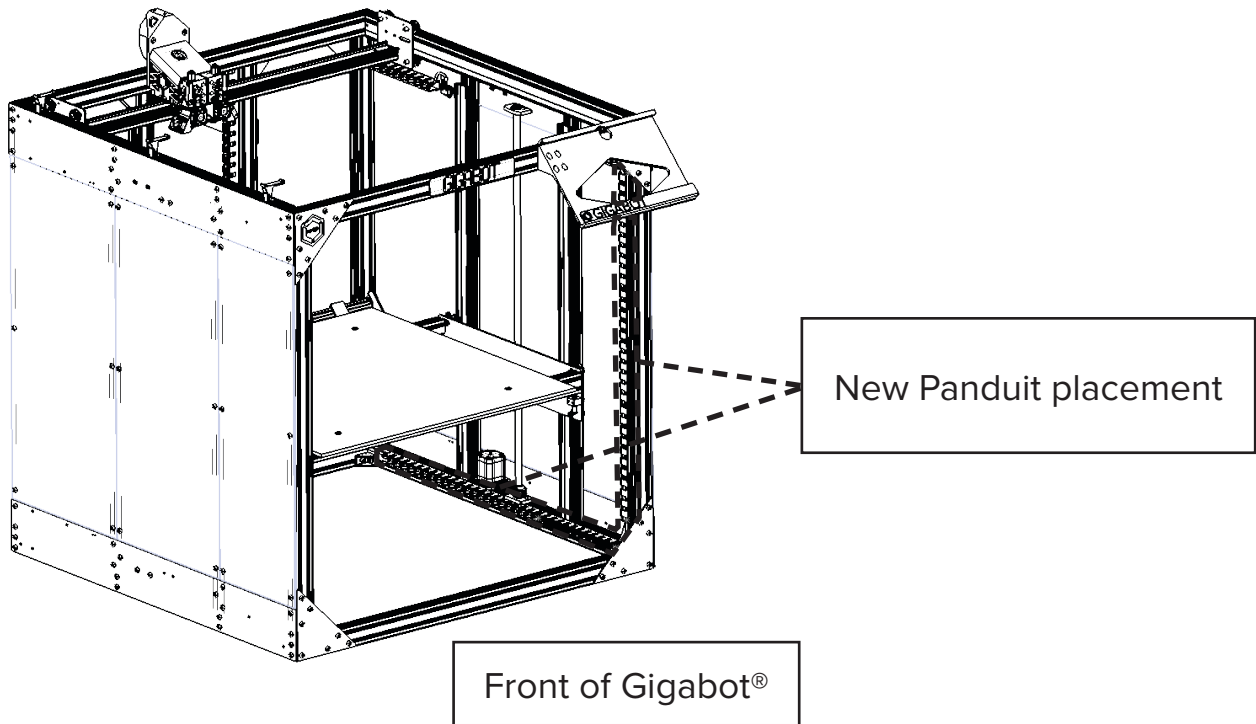

**Full Gigabot® rendering is for illustrative purposes only and may not reflect the final construction of your Gigabot®*

LEGEND

DISCONNECT



CONNECT

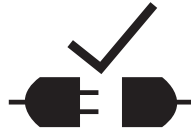

UNFASTEN/UNSCREW

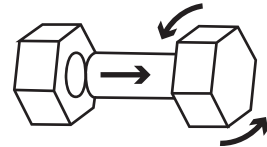

FASTEN/SCREW

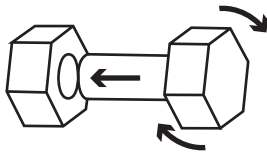

INSERT

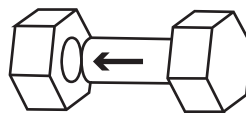

PLACE

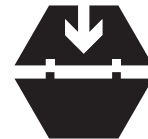

REMOVE



HOME Z AXIS



EVENLY SPACE



ROUTE



HOLD



MEASURE



Objects of importance are outlined with dotted lines

DRILL



MOVE BED

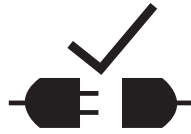

MARK

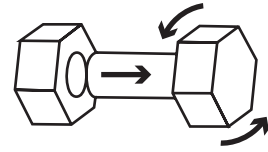

ALIGN



INSERT

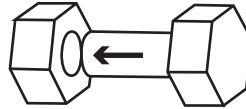

PLACE

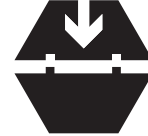

MOVE BED



MARK



DRILL



BEFORE YOU BUILD

IT'S HIP TO BE SQUARE!



When assembling the Gigabot[®], it is essential to work on a flat surface and to carefully square perpendicular parts as much as possible. This is especially important while assembling the side plates, Z-axis uprights and vertical common rails, bed frame, upper and lower cross rails, and bridge assembly. Use large clamps to help square up frames if needed.

Make good use of grease during assembly. These will help hold the eccentric spacers when installing the V-groove wheels and also keep them from damaging the side plates or end trucks during adjustment. Likewise, it will ensure smooth, quiet operation when applied to the Z-axis ACME threaded rods.

THE USES OF GREASE



T-NUTS, HOW DO THEY WORK?

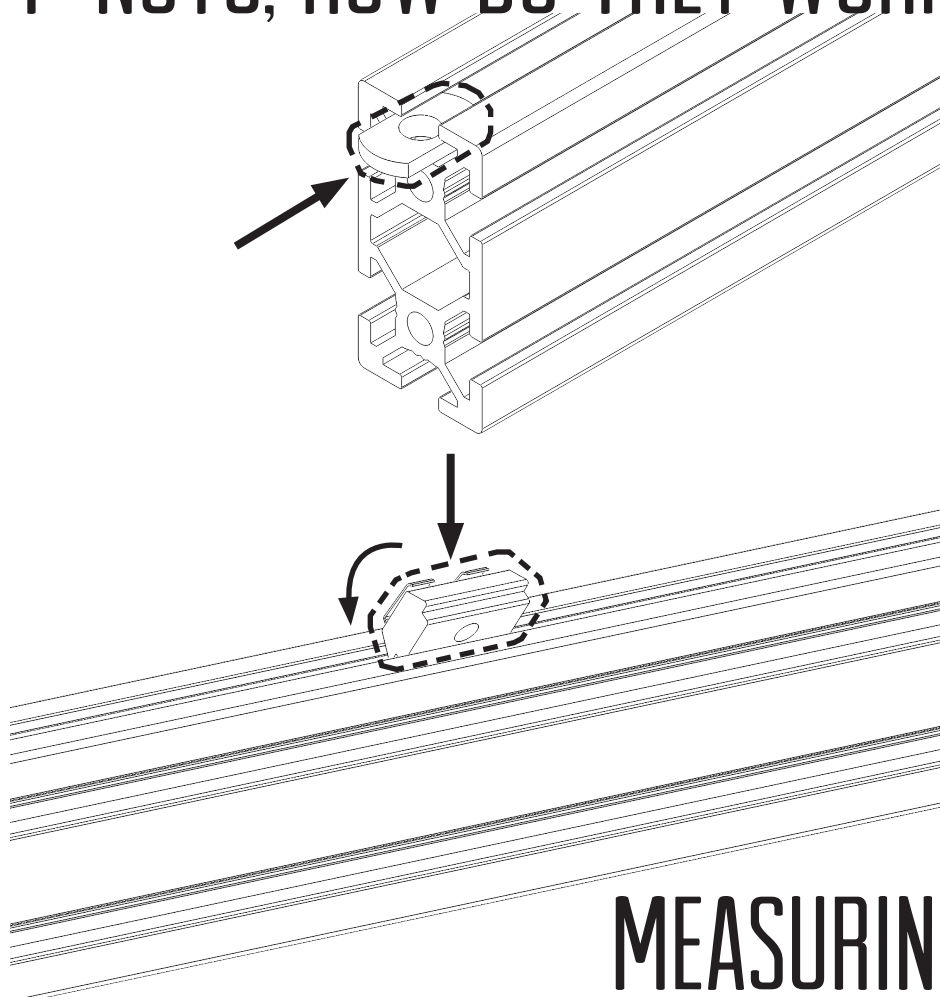

T-nuts are an essential part of assembling the Gigabot®. These are inserted into the aluminum extrusion in order to fasten parts to the frame. Post assembly T-nuts are also used. These hold their positions well without sliding around, and are useful when installing retrofits.

MEASURING AND MARKING

There are parts of the instructions that suggest marking spots on the Gigabot® to properly place parts. When marking, be sure to only use a pencil--using a permanent marker will leave unsightly marks on the metal!



BUILD GUIDE

BILL OF MATERIALS

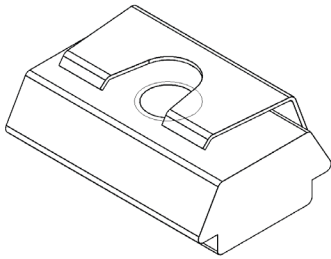

Post assembly T-nuts

6

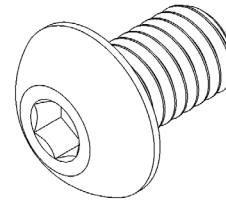

M5x8mm BHCS

8

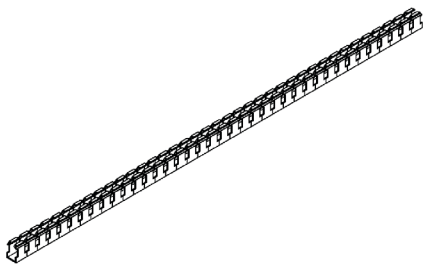

30"/762mm Panduits

2

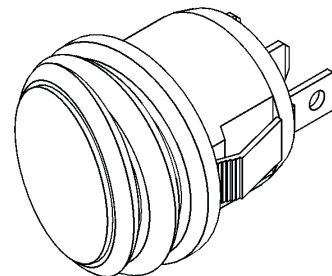

Rocker switch

1

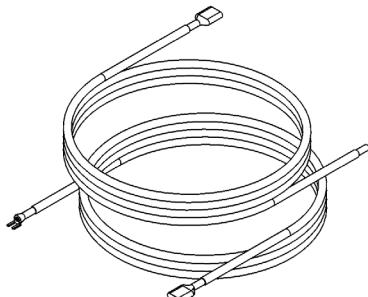

Additional power switch wiring

2

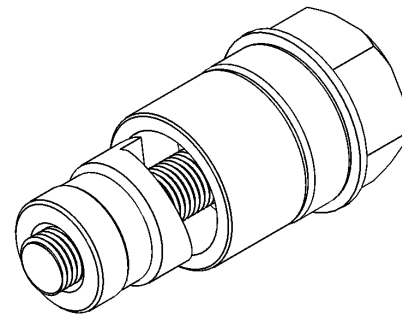

*Manual knockout punch**

1

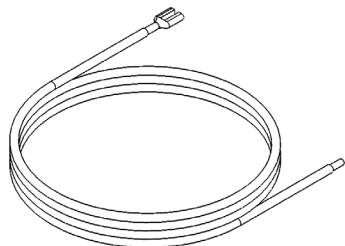

Additional Z limit switch wiring

2

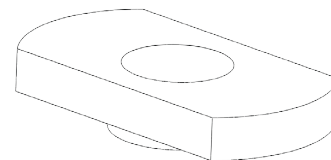

M5 T-nuts

2

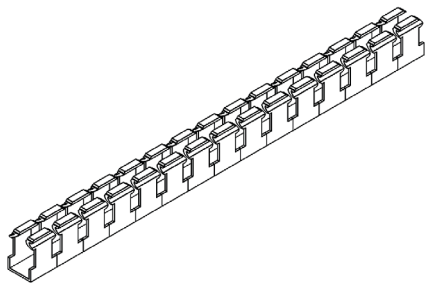

11.75"/300mm deep Panduit

6

*Manual knockout punches will be loaned out with a deposit. You must return the punch to receive your deposit back.

TOOLS YOU'LL NEED

- 3MM AND 1.5 ALLEN KEY
- 5/16" OR 8MM WRENCH
- NEEDLE NOSE PLIERS
- CRESCENT WRENCH
- POWER DRILL
- 3/8" AND 1/8" DRILL BIT
- RIGHT ANGLE SCREWDRIVER
- SMALL FLAT HEAD SCREWDRIVER
- SMALL PHILLIPS HEAD SCREWDRIVER

A : REMOVAL AND REPLACEMENT

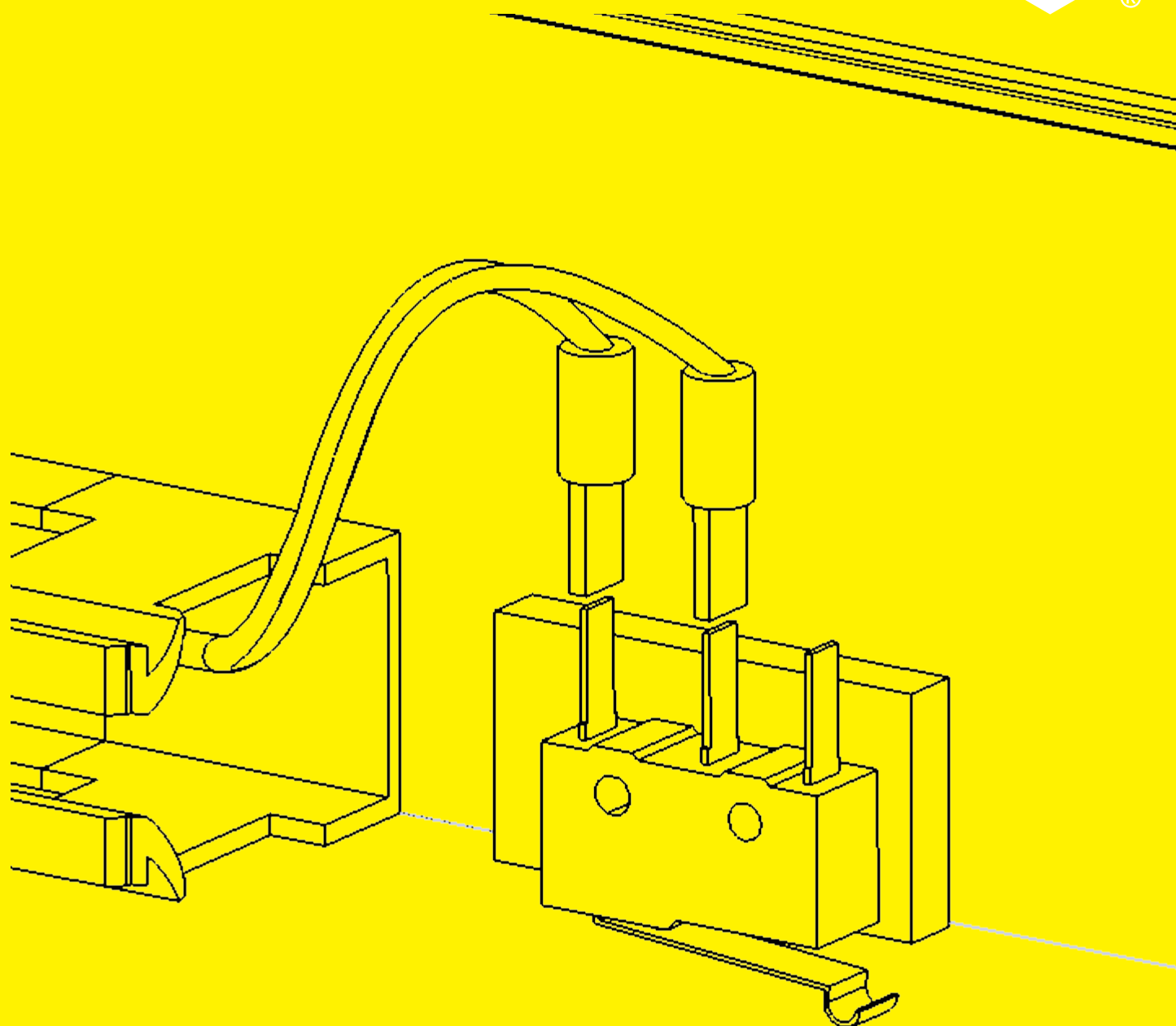

A1



Home bed for easier access to Panduits

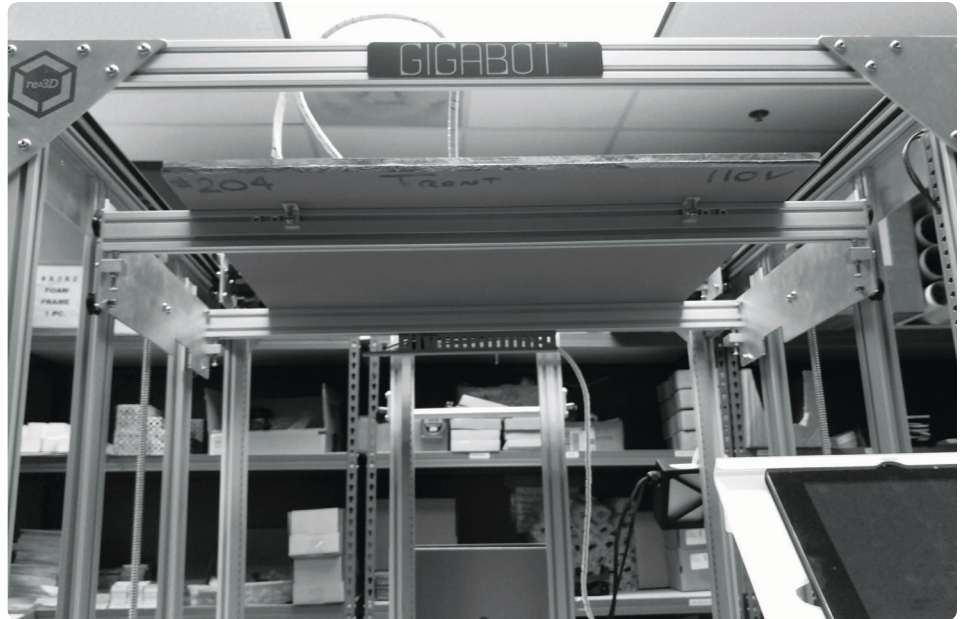

WARNING

PLEASE be sure that you have turned off and unplugged your Gigabot before attempting any modifications!

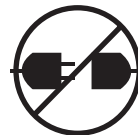

A3



Remove Panduit covers on Panduits leading to Z limit switch (bottom cross rail, rear right vertical common rail, and top right common rail)



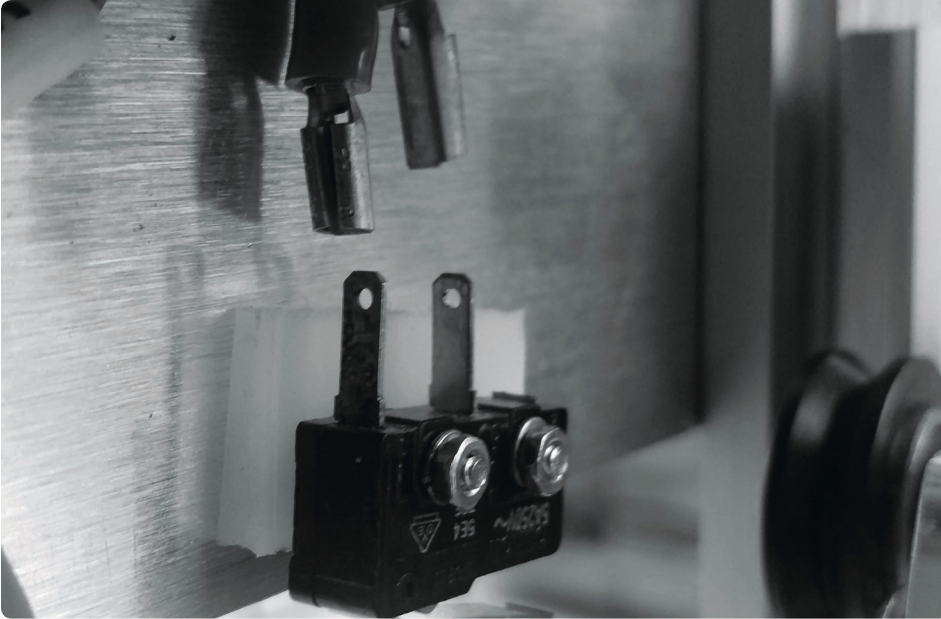

A4



Disconnect wires from Z-limit switch and remove from Panduits, leave connected @ electrical box for reference

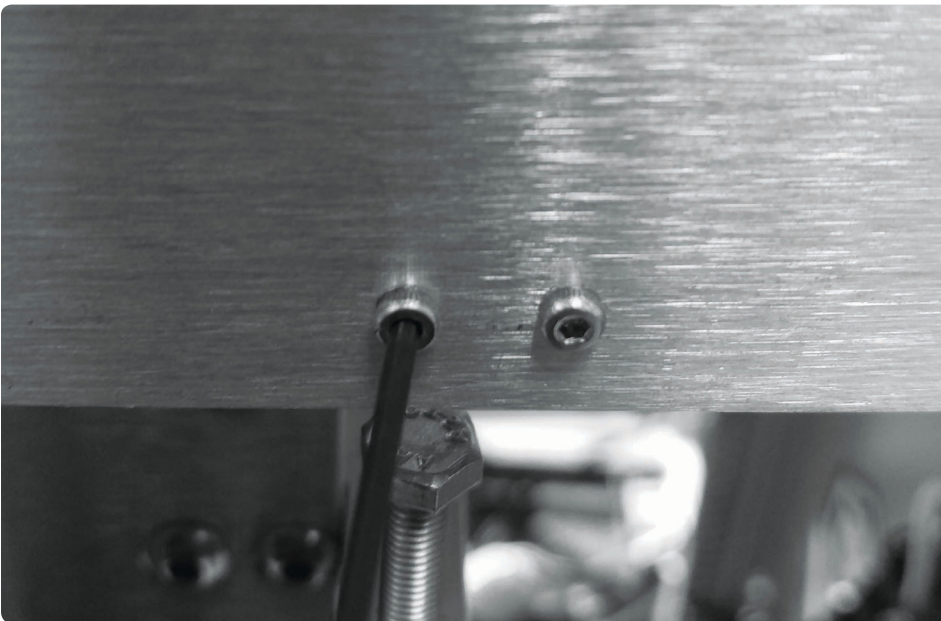

A5

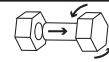

Using a 1.5mm Allen Key, unscrew M2x16mm SHCS on limit switch to remove. Be careful not to drop or lose the M2 nut and lock washer

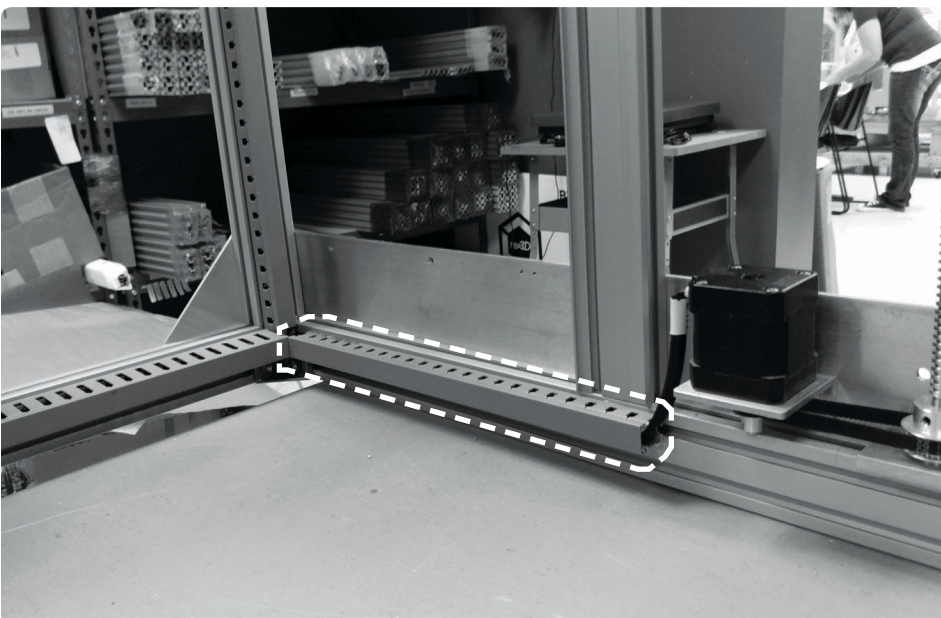

A6



Remove 11.75" Panduit on lower right side panel

A7

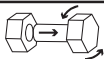

Using 3mm Allen Key, unscrew and remove M5x12mm BHCS on leveling block for Z limit switch on rear right of bed frame

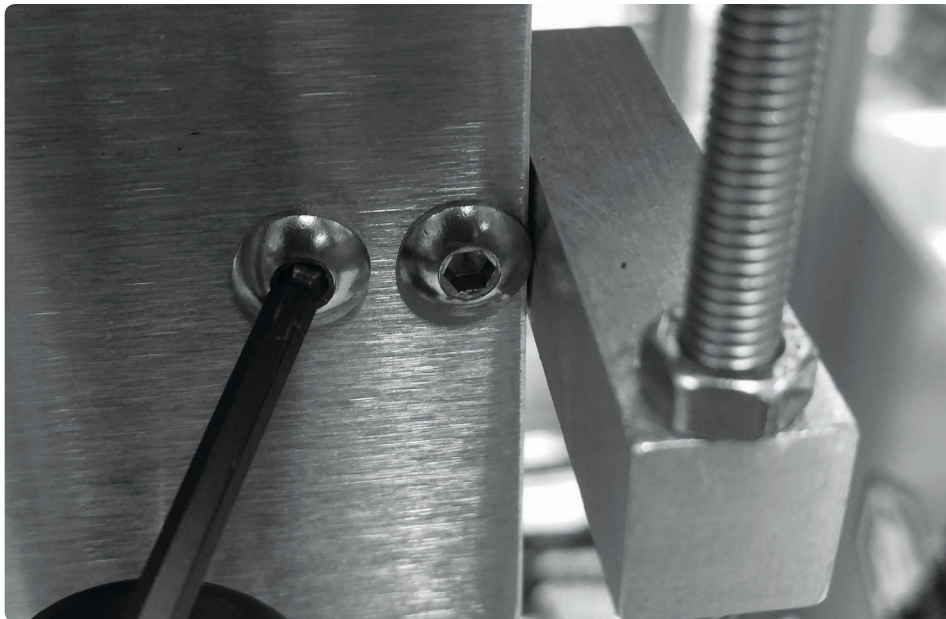

A8

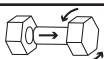

Unscrew and remove bed leveling screw. Be careful not to drop the M5 washer or spring

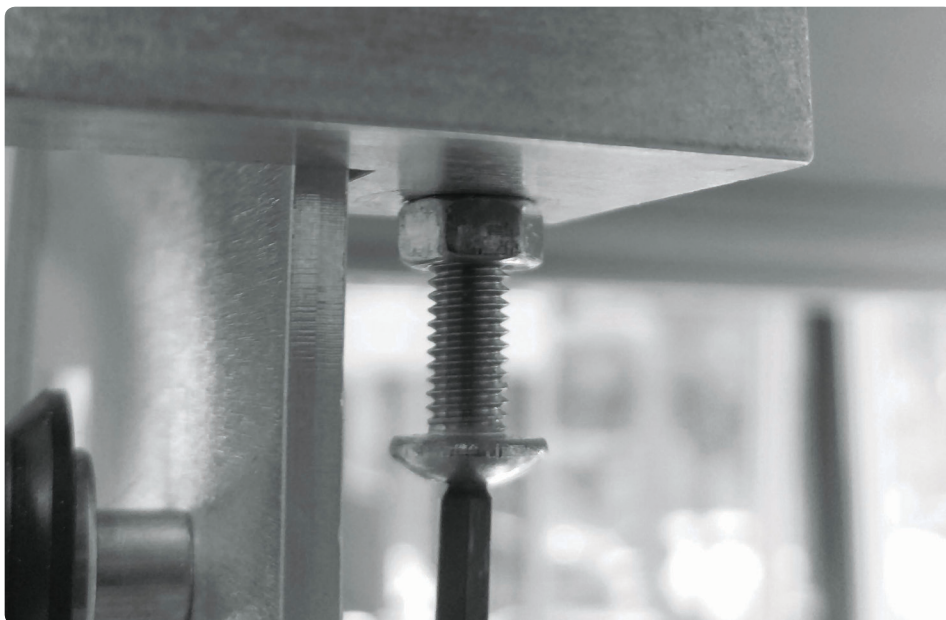

A9

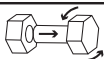

Using the 3mm Allen Key, unscrew and remove the M5x12mm BHCS from the front right leveling block



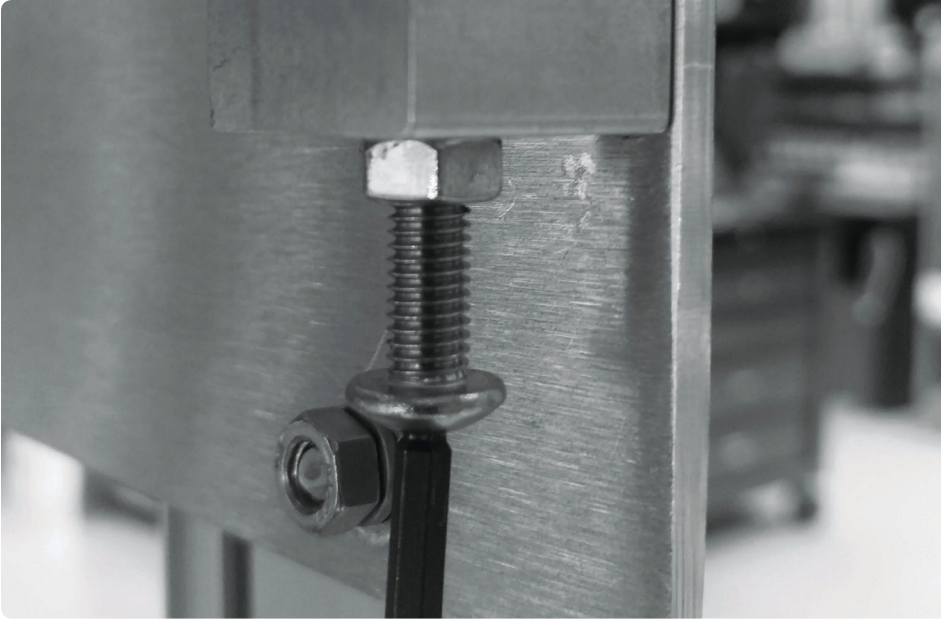

A10

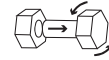

Unscrew and remove bed leveling screw. Be careful not to drop the M5 washer or spring



A11

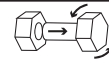

On leveling block for Z limit switch, unscrew and remove bolt. Use a 5/16" or 8mm wrench if very tight

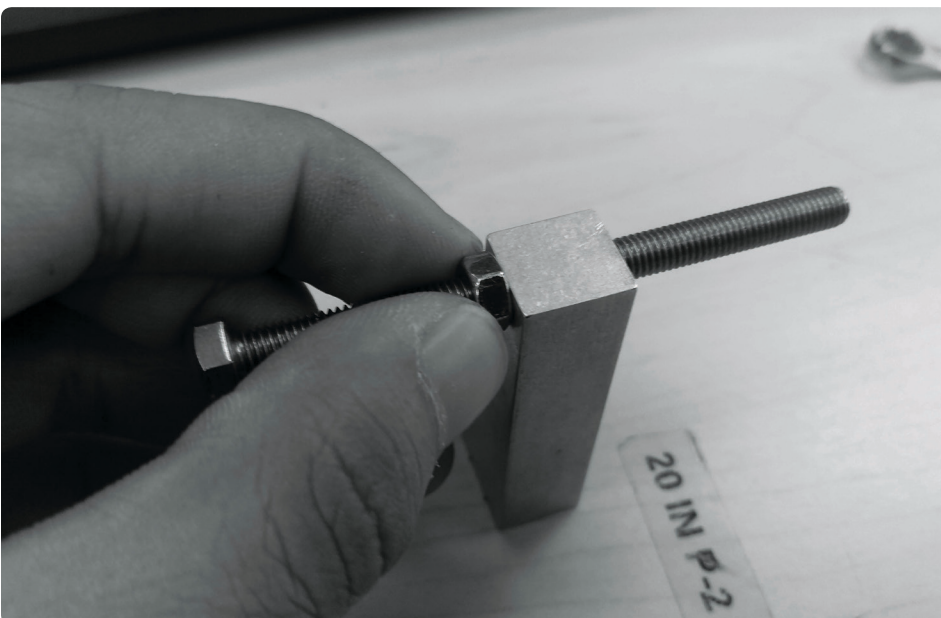

A12

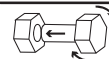
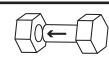

Reinsert from the opposite side. Fix into place by hand tightening the M5 nut

B : DRILLING EXTRA HOLES

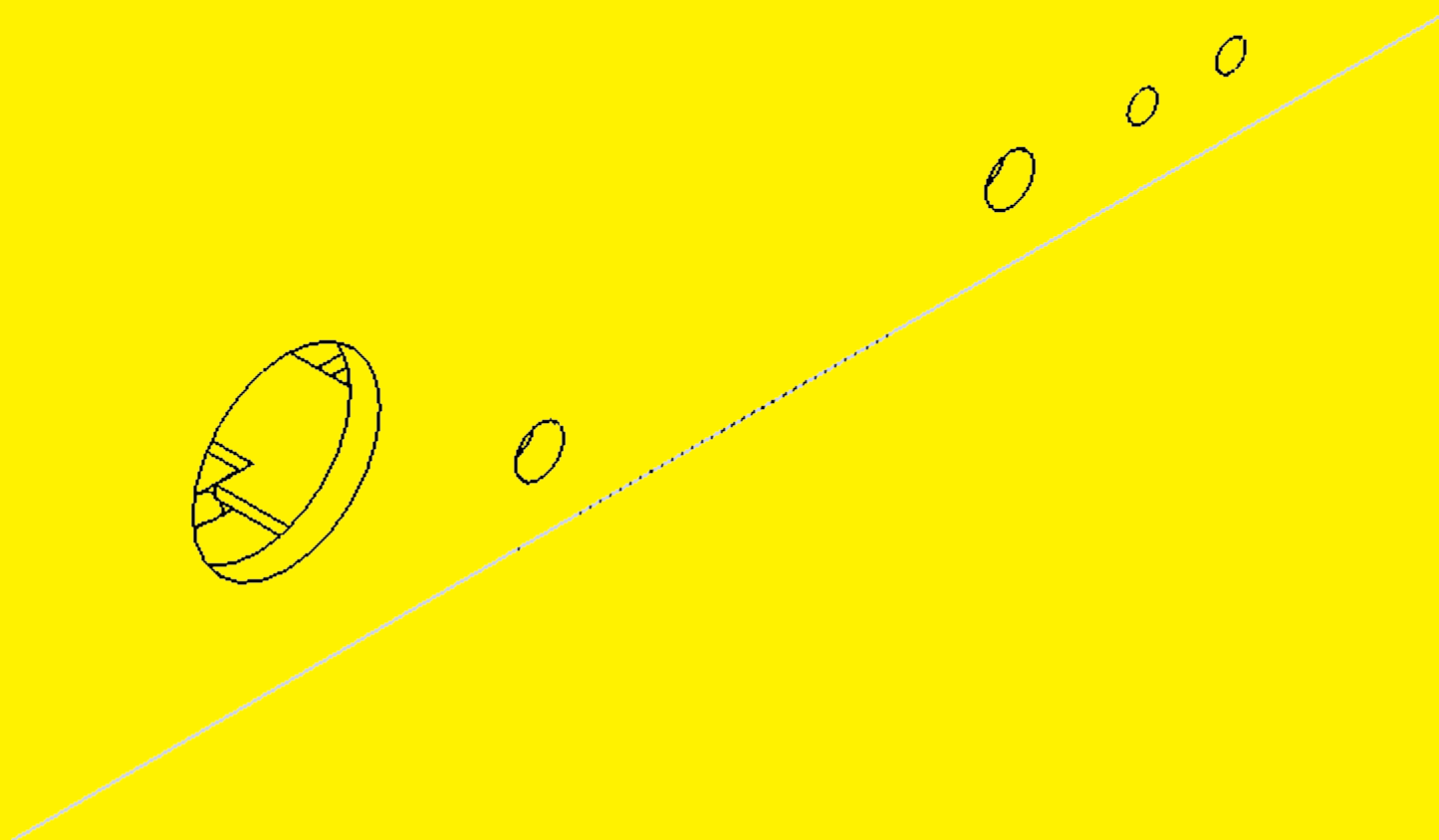

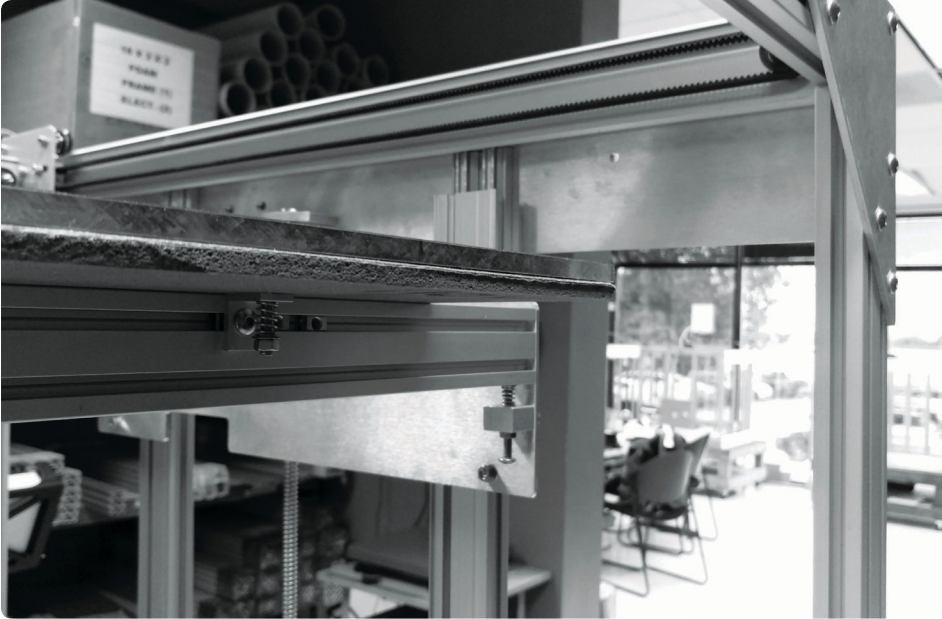

B1



Move bed to access side plate

WARNING

PLEASE be sure that you have turned off and unplugged your Gigabot before attempting any modifications!

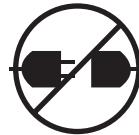

B3

Use something to keep metal shaving out of lower Panduits. Here, we used a folded 8.5"x11" piece of paper as a cover

B4

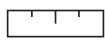

Mark hole centers according to diagram. These include power switch, Panduit, and limit switch

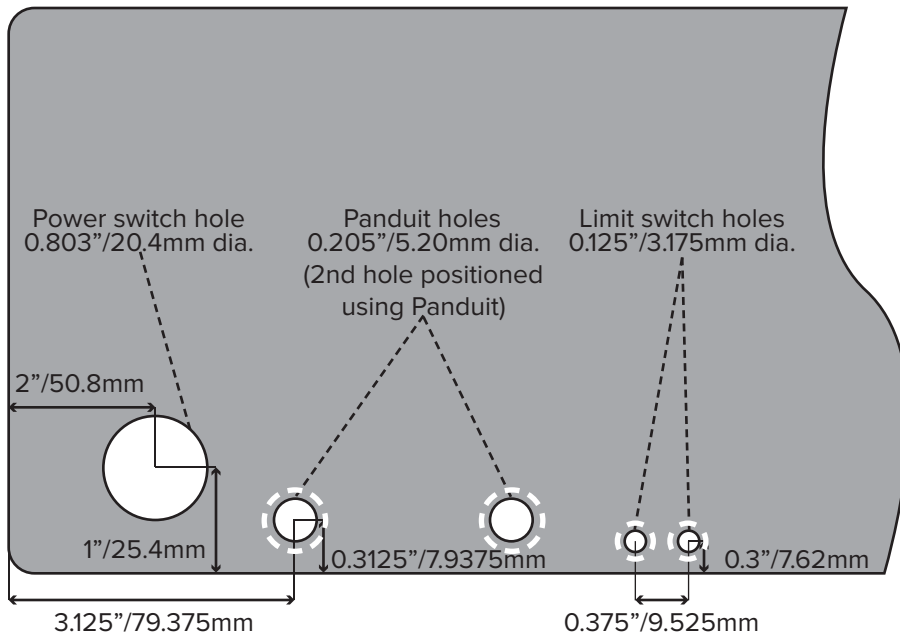

B5



Mark the left hole for the Panduit. Use the actual Panduit to mark the desired spacing for the second hole

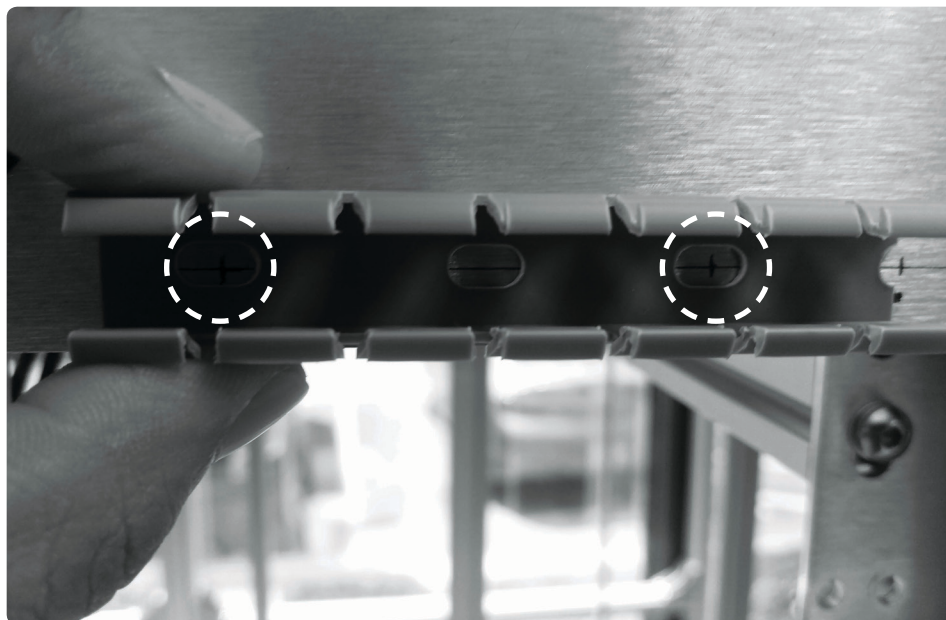

B6



Mark 2 holes for the limit switch

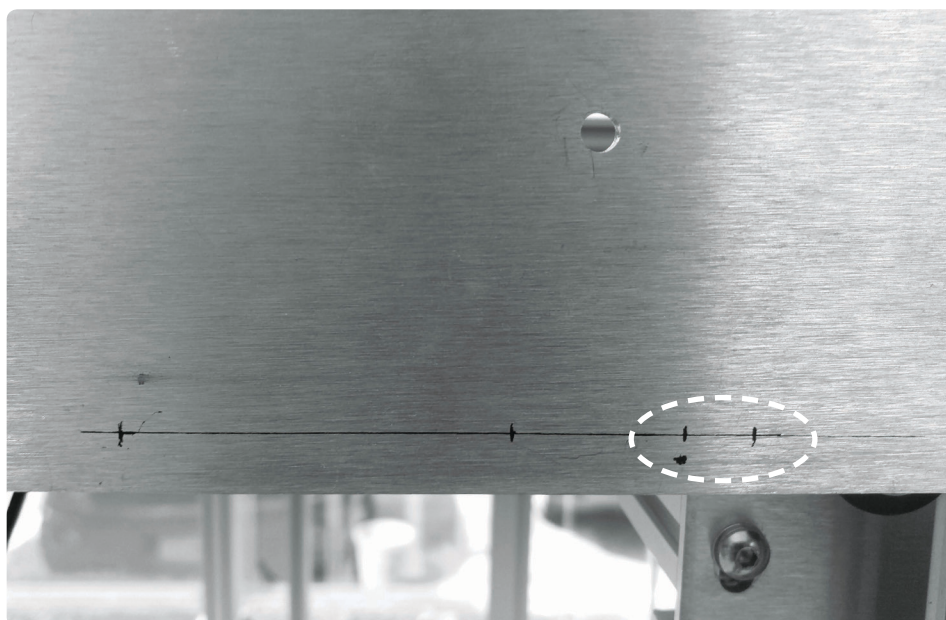

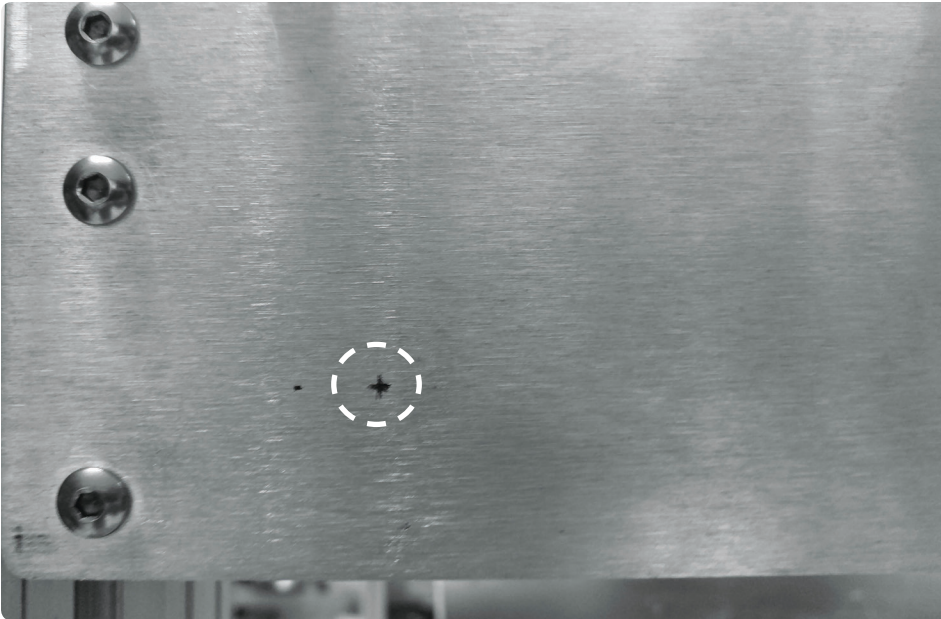

B7



Mark power switch hole

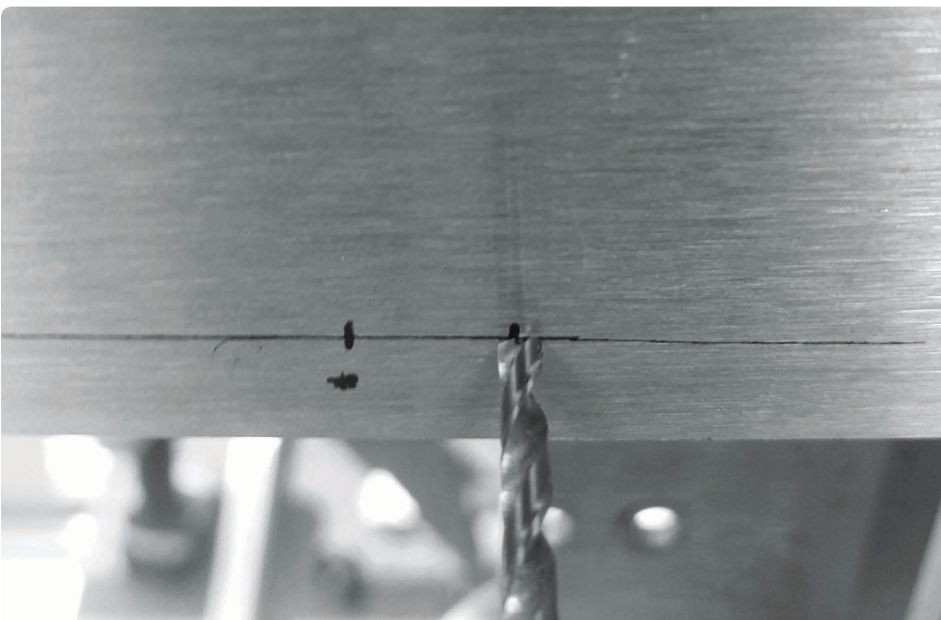

B8



Drill limit switch holes with
1/8" bit

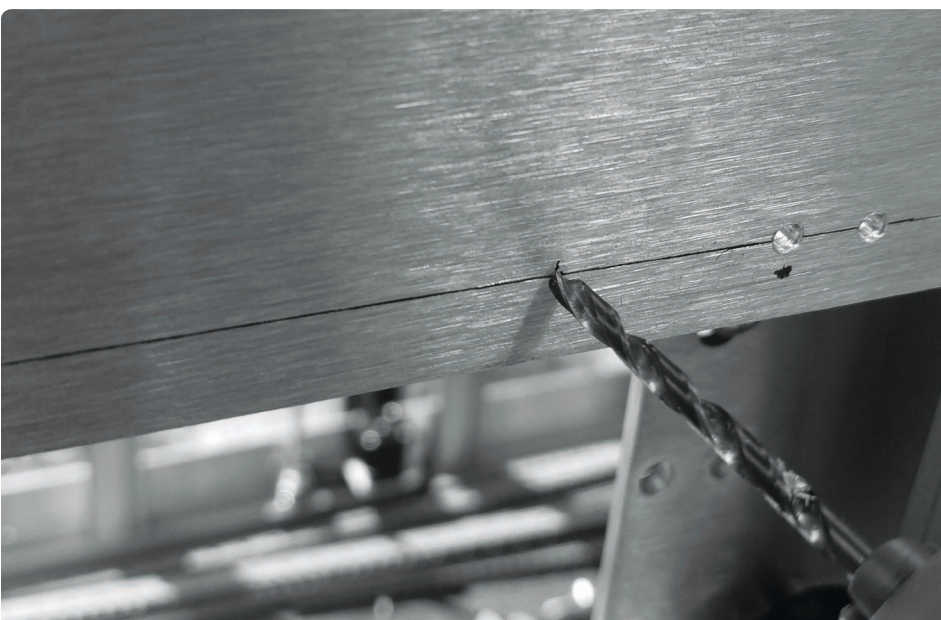

B9



Go ahead and drill pilot
holes through all of the
other marks

B10



Drill Panduit holes with a #5
(0.205") bit

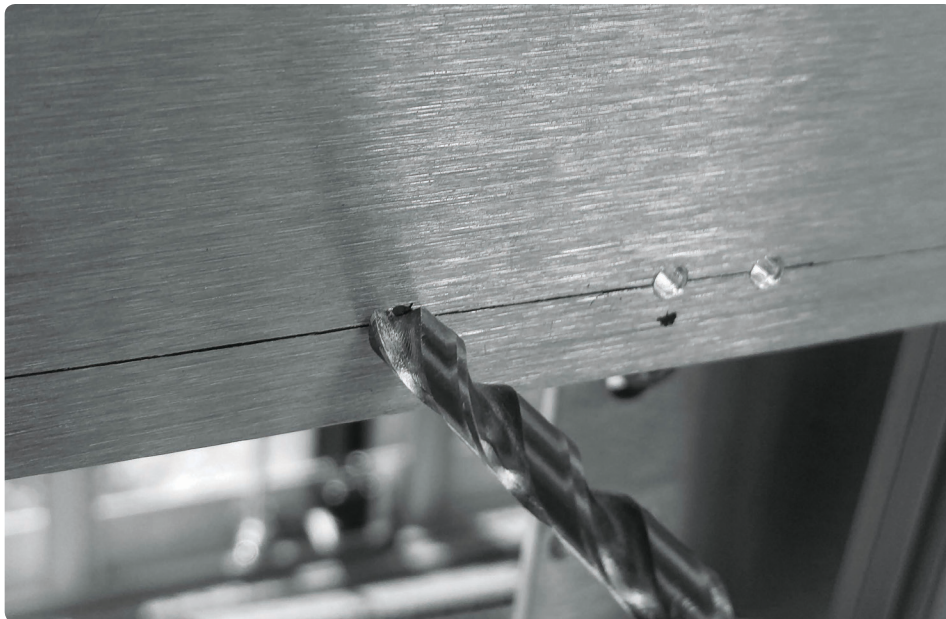

B11



Drill power switch hole with
3/8" drill bit

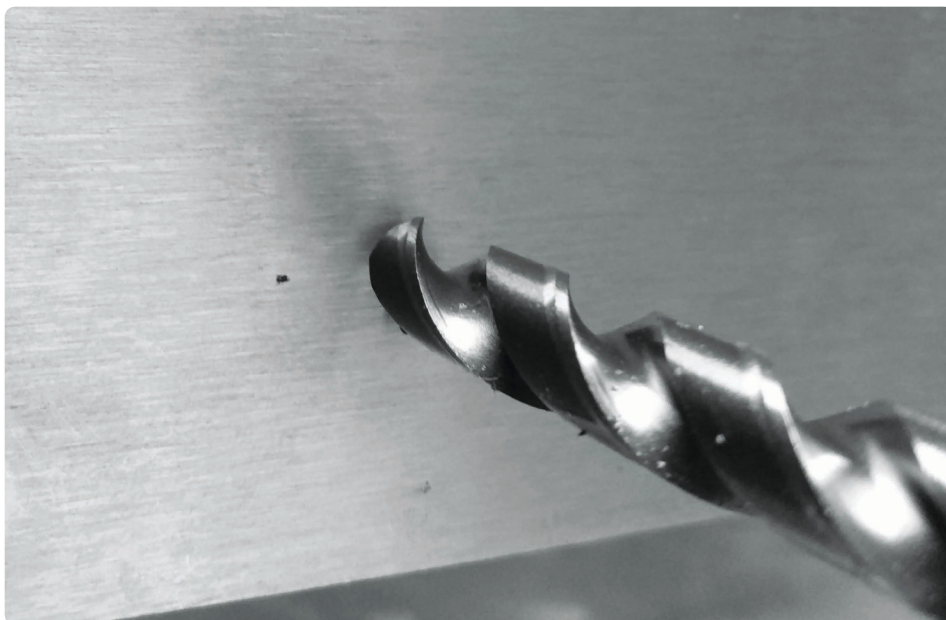

B12

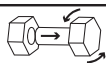

Unscrew the manual hole
punch





B10



Separate punch from threaded draw stud and die

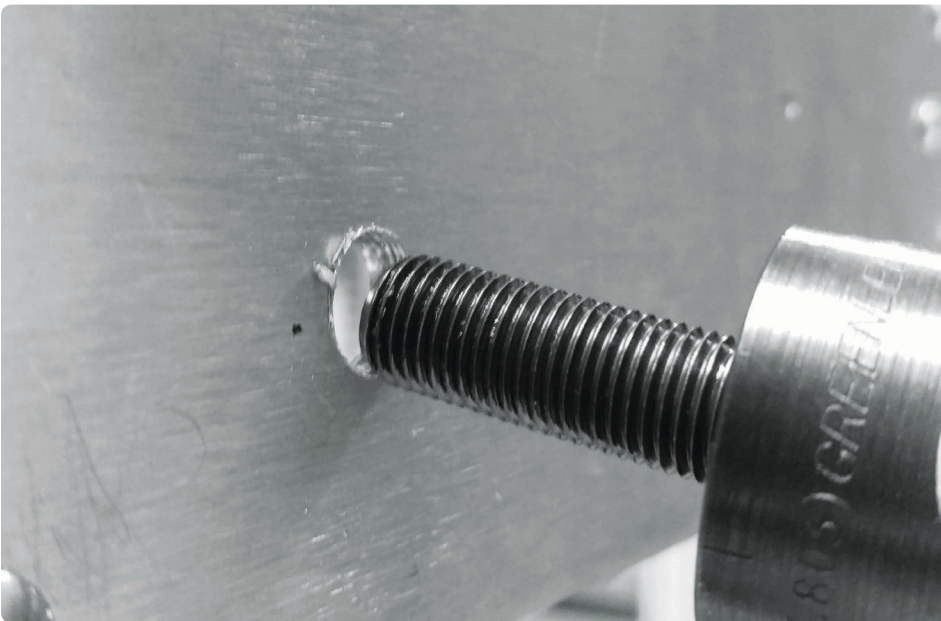

B11

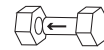

Fit the draw stud and die through the 3/8" hole



B12

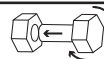

Screw the pieces back together

B13

Note that the side with the large bolt head should be on the outside of the side plate for easy accessibility



B14



Using one hand, hold onto the punch for stability



B15

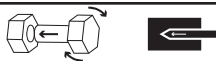

Use a crescent wrench to manually tighten (clockwise) the punch until the hole is made



Be careful-once the hole is made, the punch may fall out of the hole

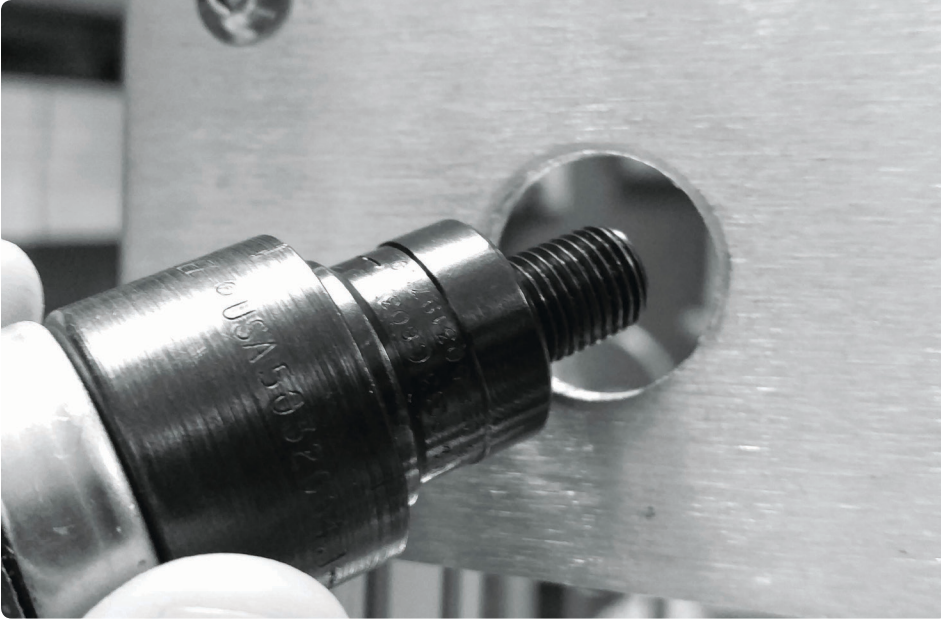

B16



Remove the punch

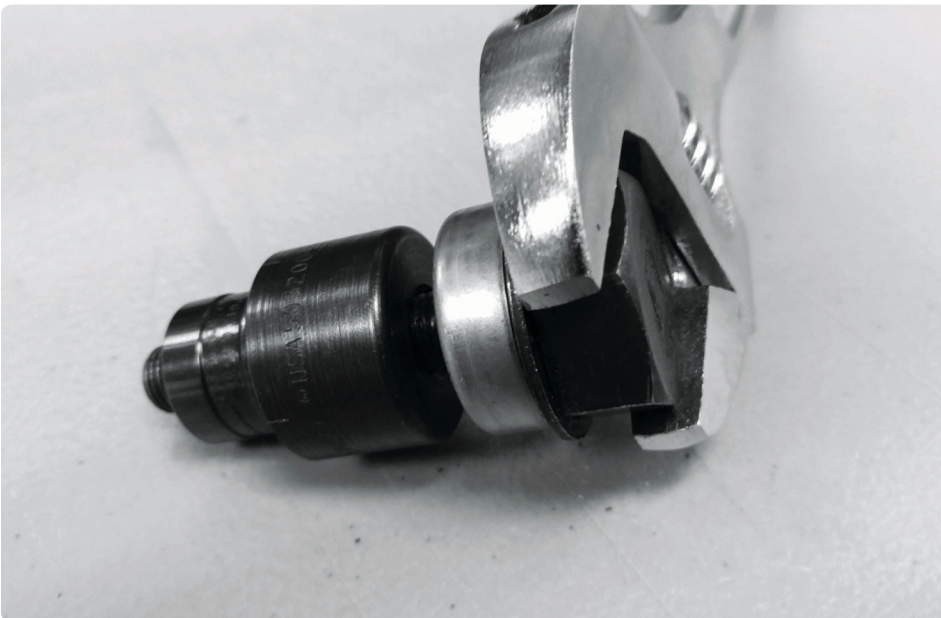

B17

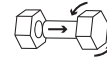

Disassemble the punch
with the wrench



B18



Remove the die from the
draw stud and empty out
the split metal slugs

B19

Deburr as needed, clean up
metal shavings



NOW IS A GOOD STOPPING POINT...

Acquire beverage of
your choice

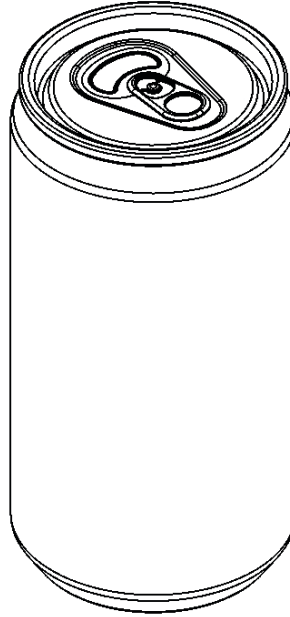

Actuate pull tab

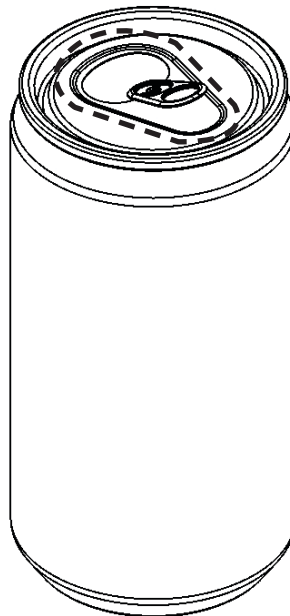

Consume

C : MOUNTING AND PLACEMENT

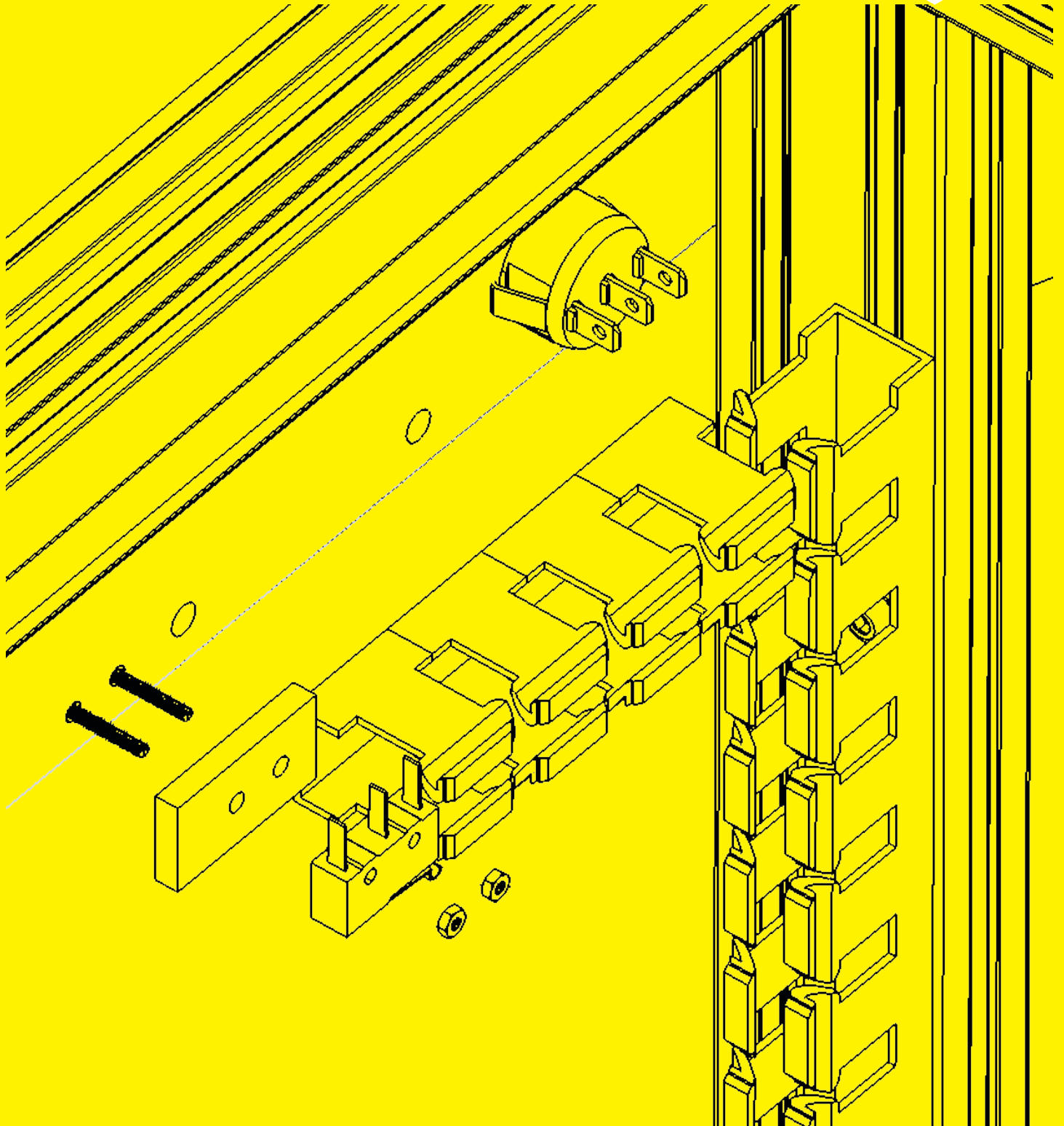

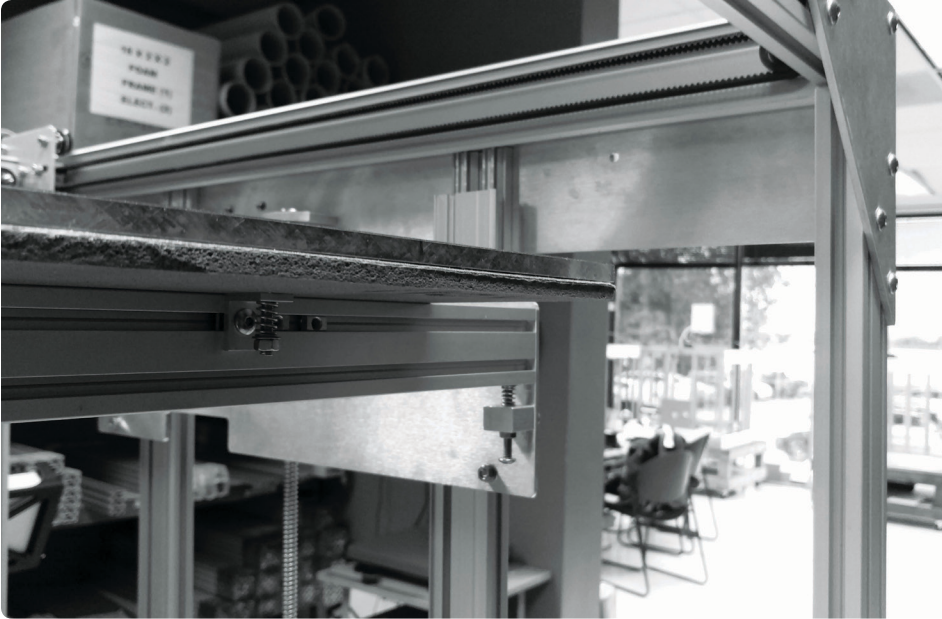

C1



Turn on Gigabot and home the bed for easy access to the lower frame

WARNING

PLEASE be sure that you have turned off and unplugged your Gigabot before attempting any modifications!

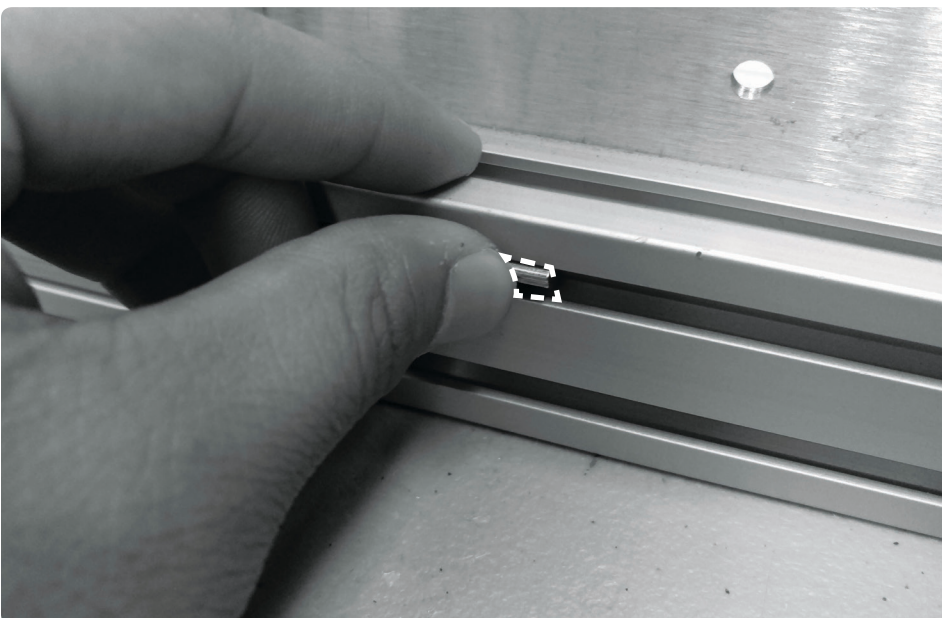
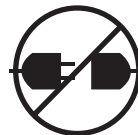

C3



Evenly space and insert 3 post assembly T-nuts on lower right common rail for 30" deep Panduit

You may also use existing T-nuts from 11.75" Panduit

C4



Mount 30" deep Panduit with 3 x M5x8BHCS using 3mm Allen Key

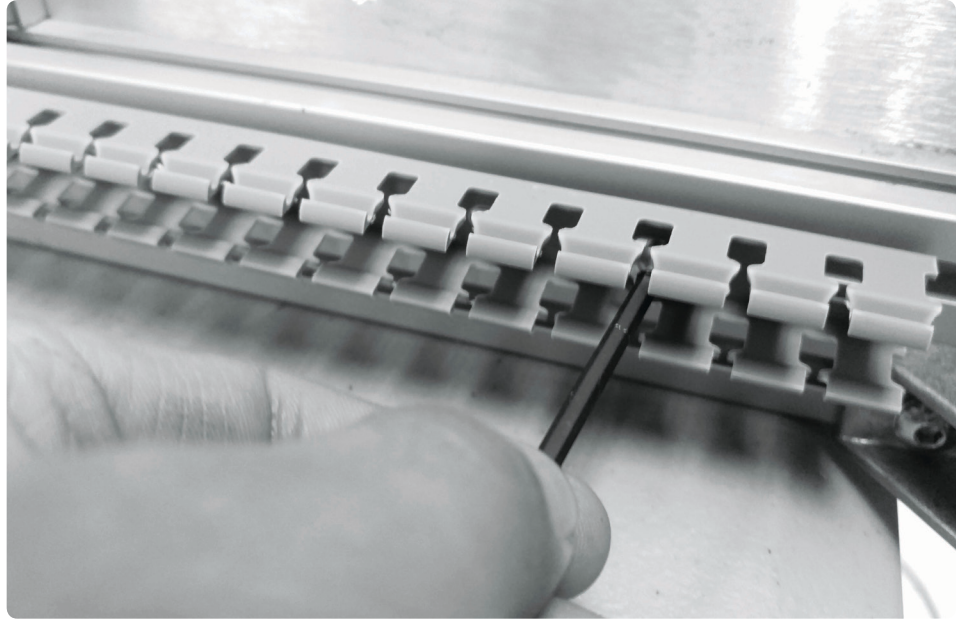

C5



Evenly space and insert 3 post assembly T-nuts on front right vertical common rail

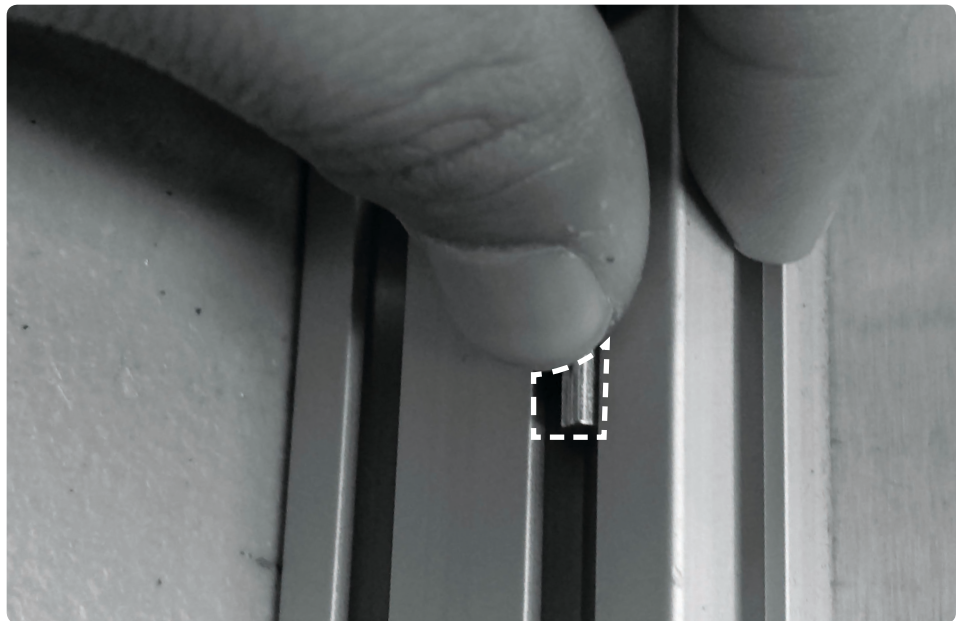

C6

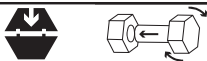

Mount 30" deep Panduit with 3 x M5x8mm BHCS using 3mm Allen Key





C7 

Insert M5x8mm BHCS in
Panduit holes

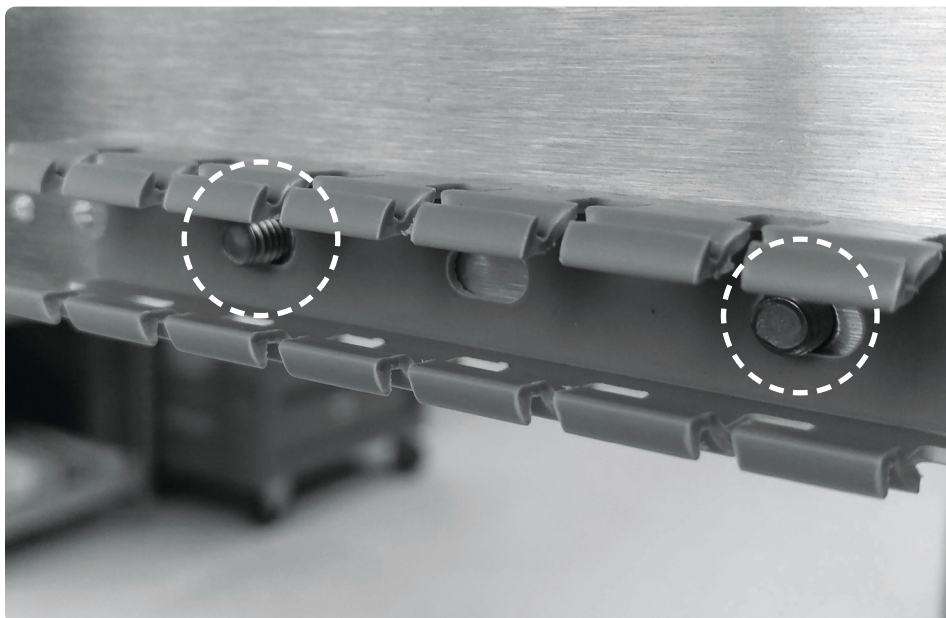

C8 

Work Panduit onto screws

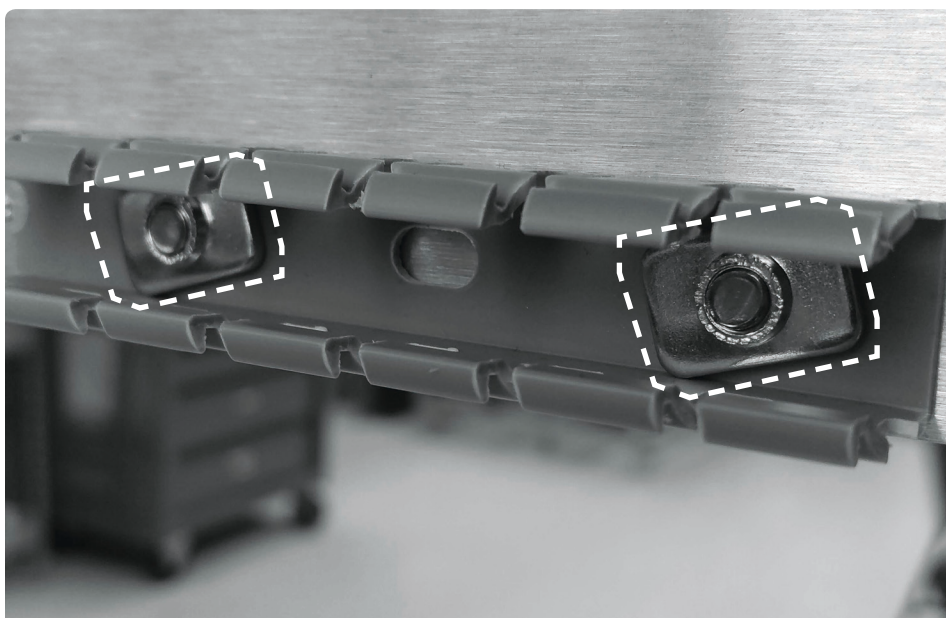

C9  

Place T-nuts and tighten

C10

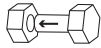

Insert 2 x M2x16mm SHCS into limit switch holes. This hardware is already with the existing Z limit switch

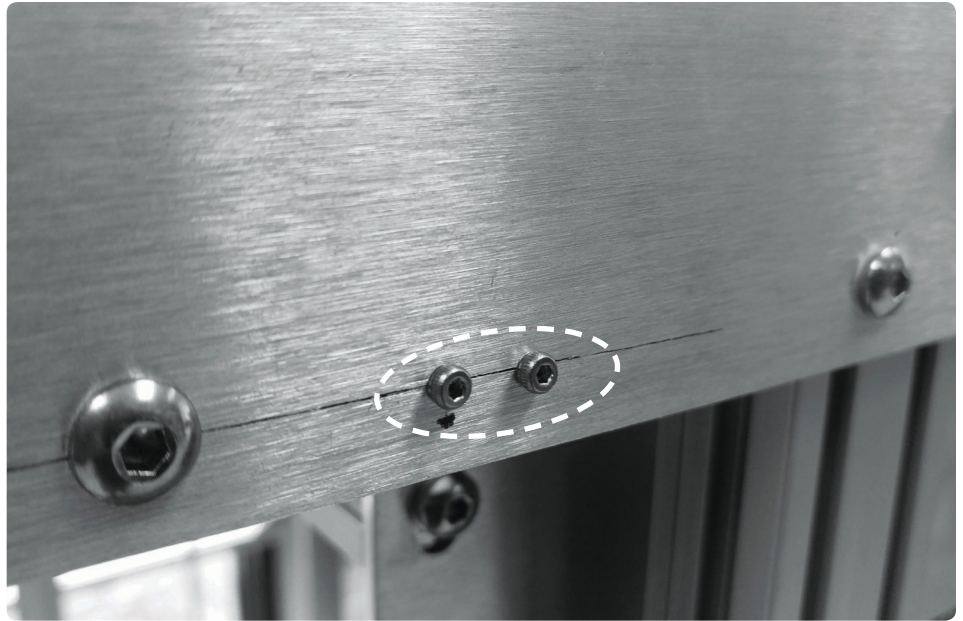

C11



Mount plastic block and limit switch onto screws

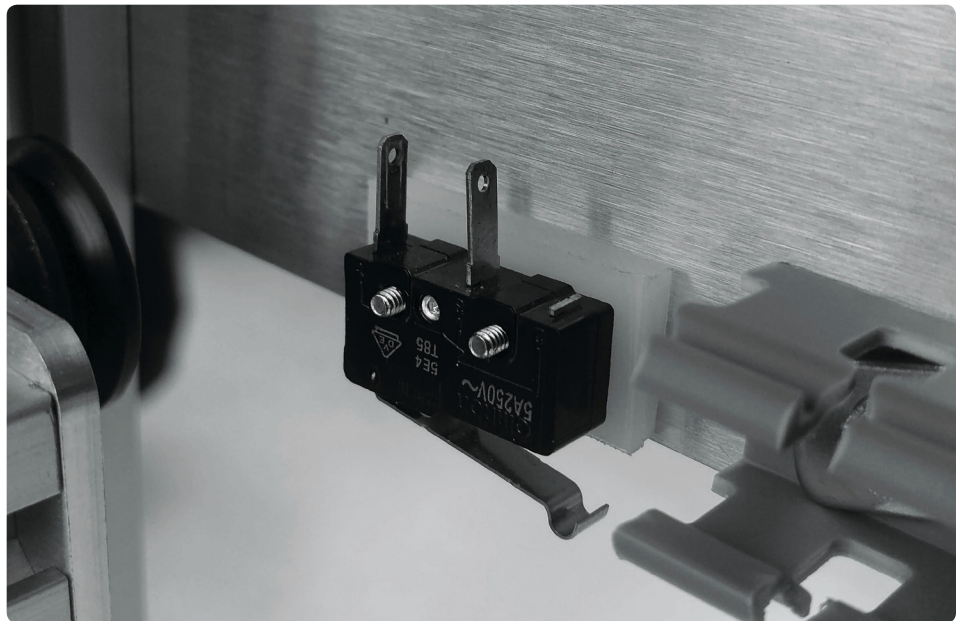

C12

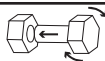

Place M2 lock washer and then M2 nut and hand-tighten. Repeat for other screw





C13

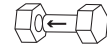

Press power switch into hole

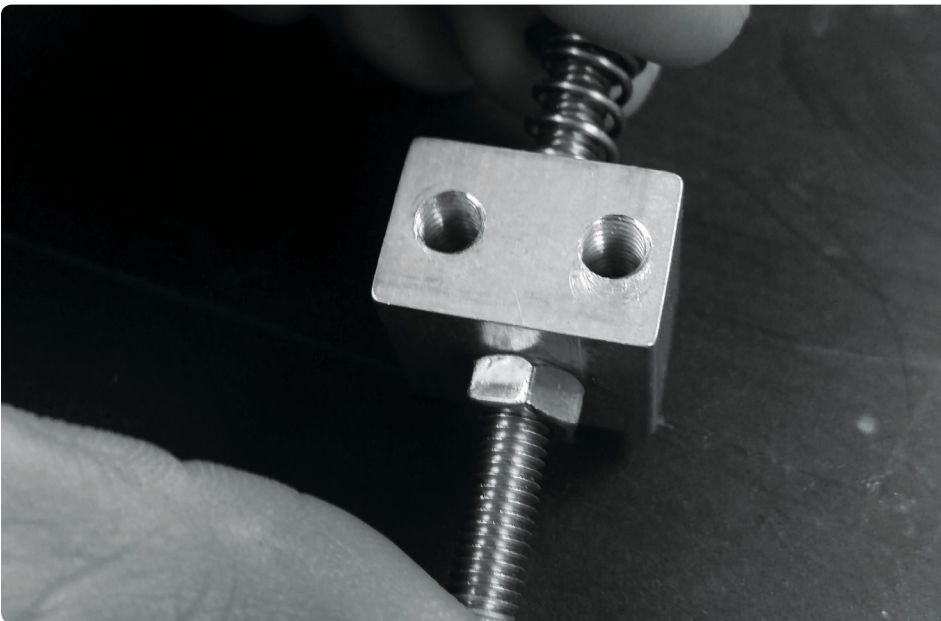

C14

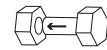

Carefully replace leveling screw through leveling block with spring and washer



C15



Insert and partially screw into T-nut on bed rail

C16



Align leveling block with
bed side plate holes and
screw in M5 screws



C17

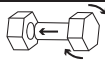

Tighten leveling screw



C18

On the Z limit switch
leveling block, the bolt
should have already been
flipped over

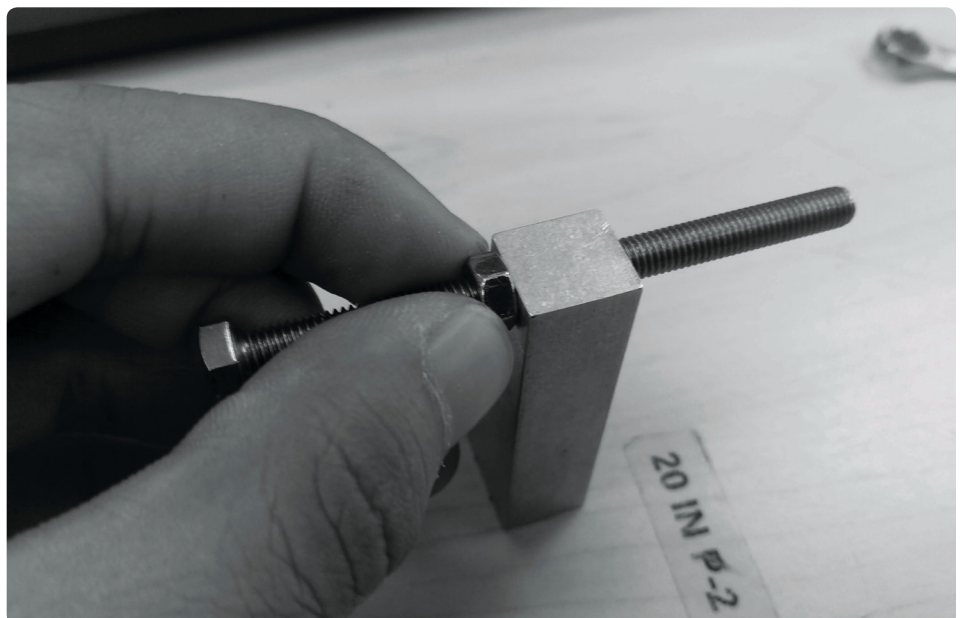

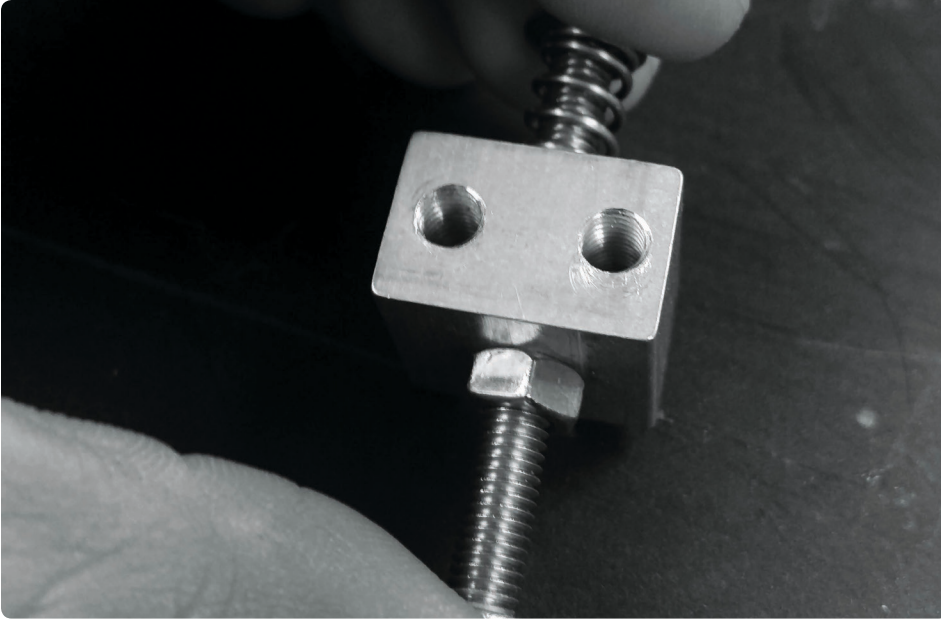

C19 

Carefully replace leveling screw through Z limit switch leveling block with spring and washer (same as normal leveling block shown here)

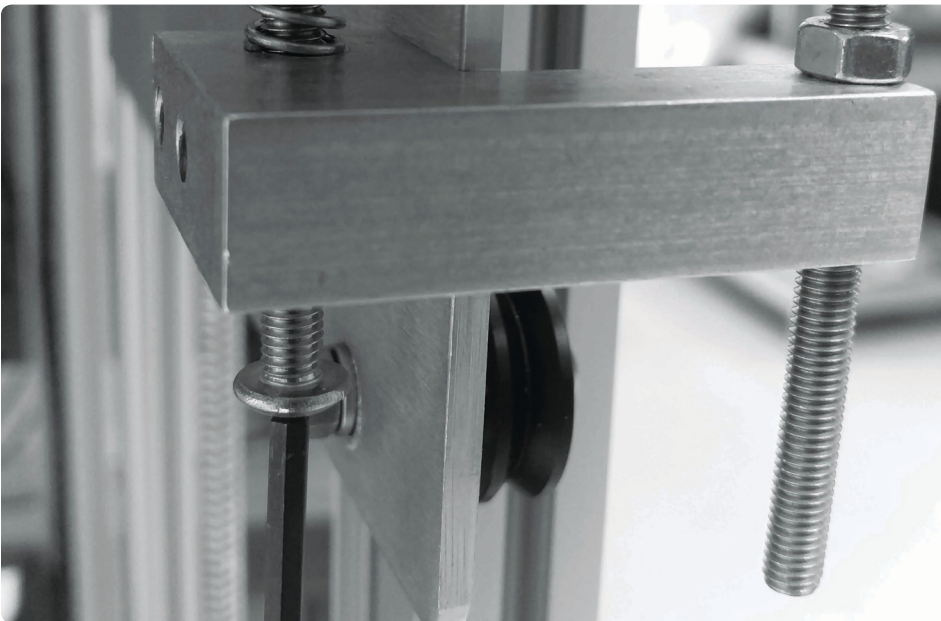

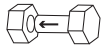
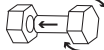
C20  

Insert and partially screw into T-nut on bed rail

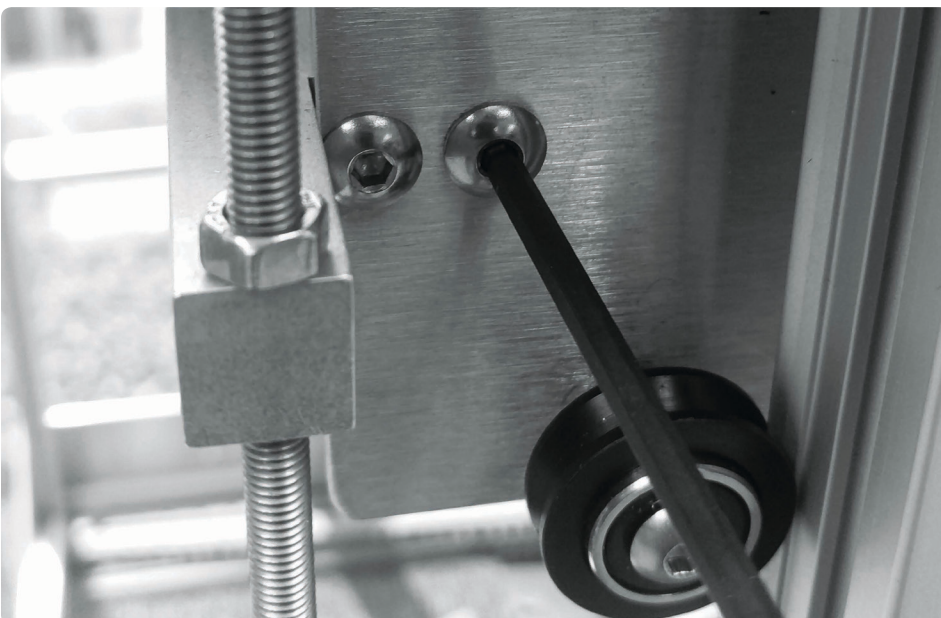

C21  

Align leveling block with bed side plate holes and screw in M5 screws

C22

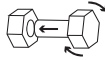

Tighten leveling screw

To be safe, make this longer than needed to ensure bed doesn't run into hot end. Fine adjust after verifying ordinary function

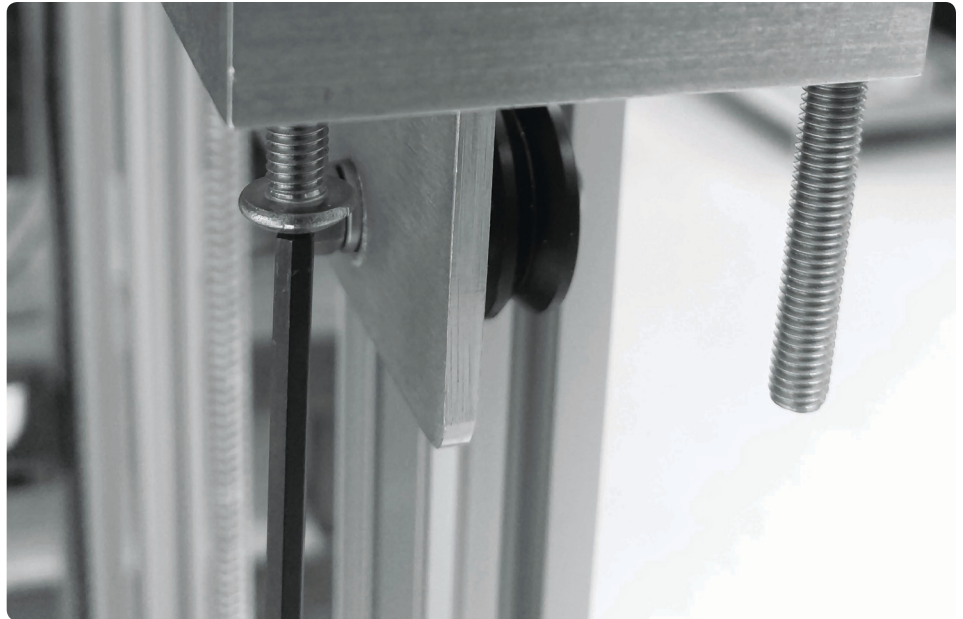

C23



Make sure bolt head is underneath limit switch

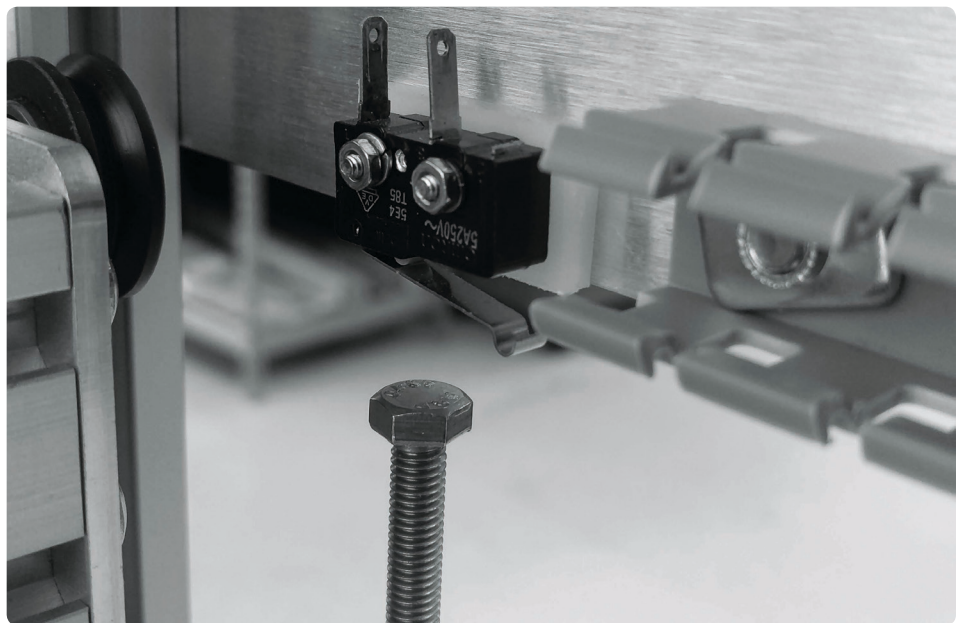

D : WIRING

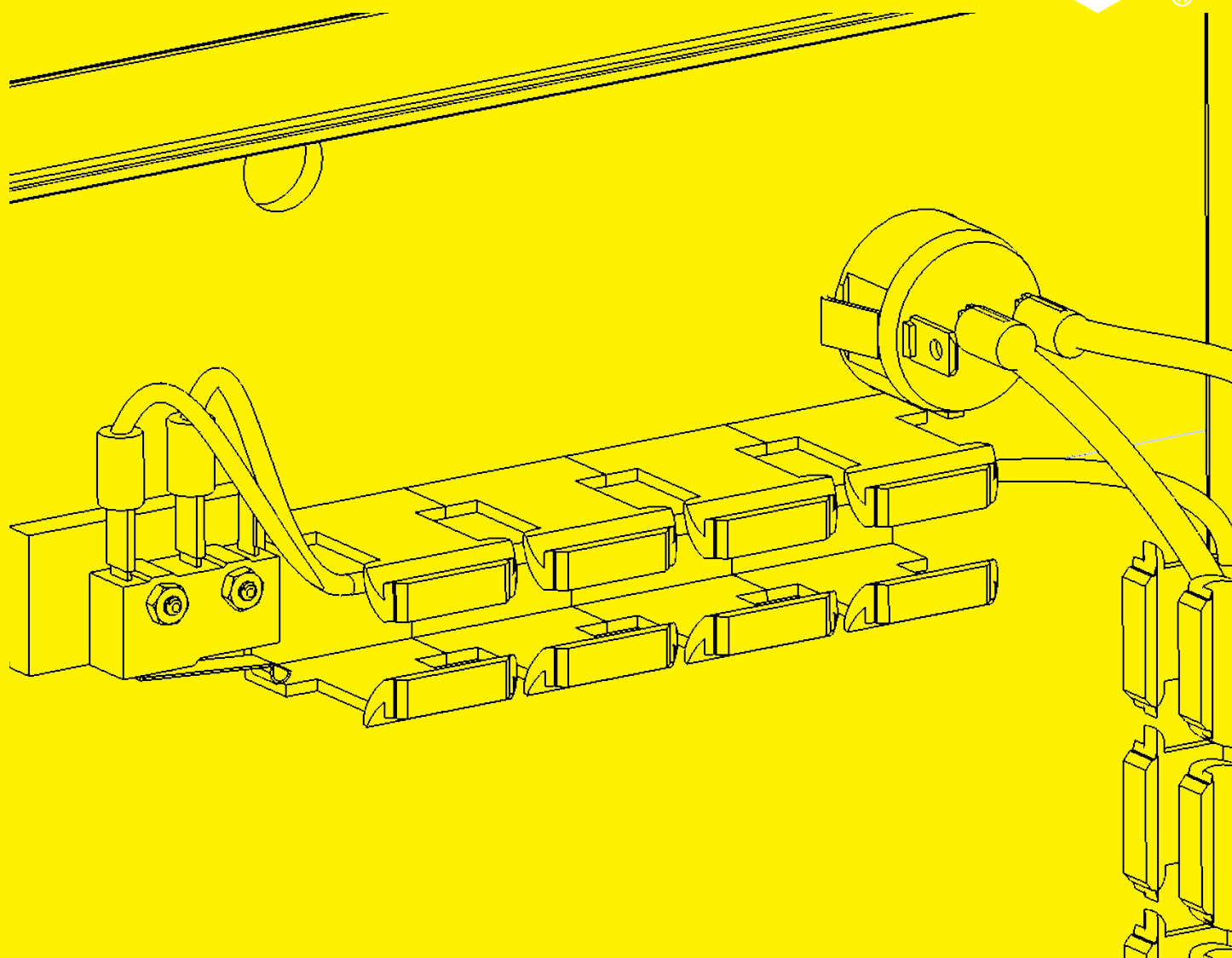

D1



Connect new Z-limit wires
as well as new power
switch wires

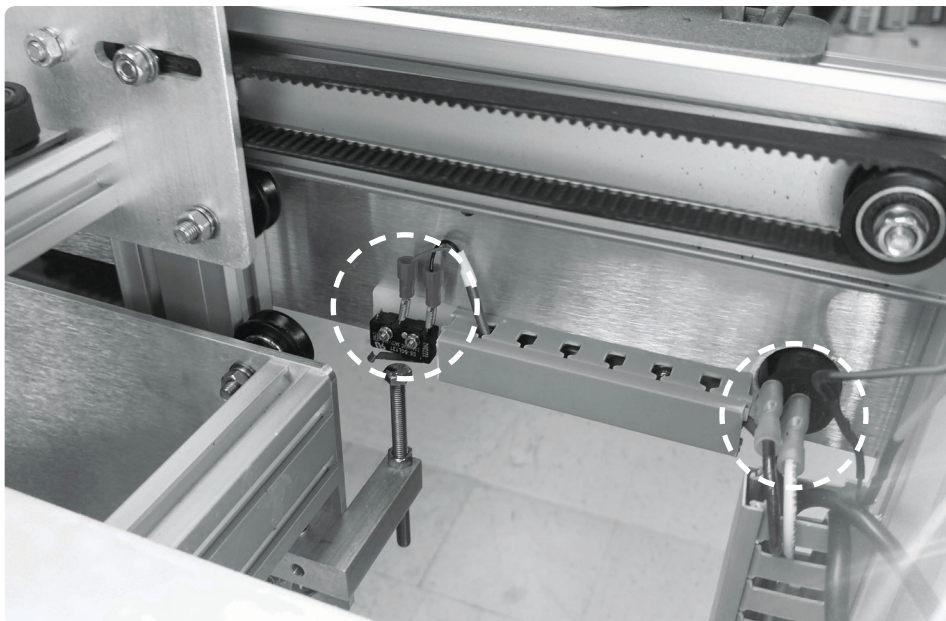

D2



Route through Panduit,
cover along the way

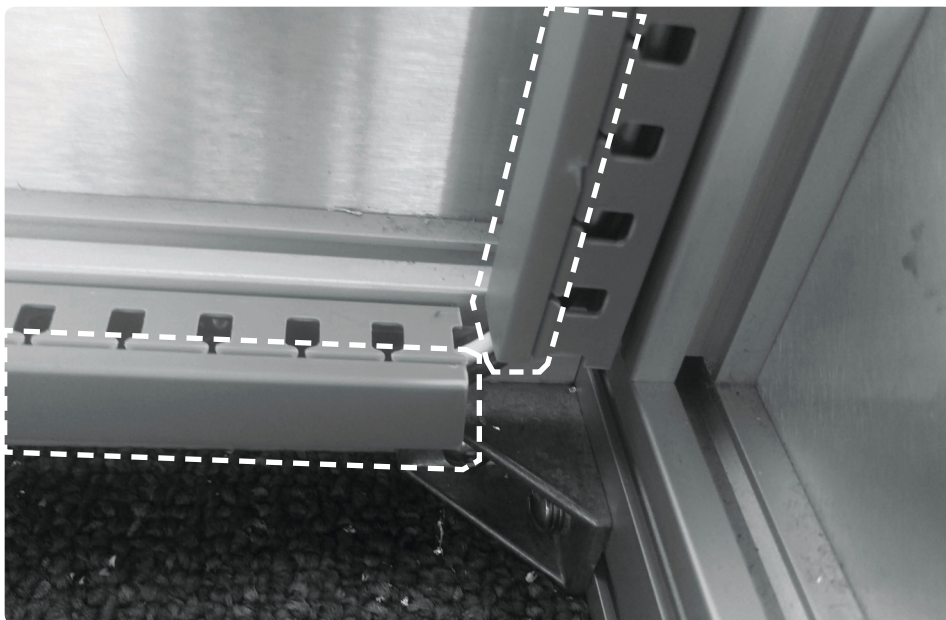

D3

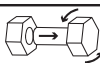

At electrical box, loosen
the grommet for the Z limit
switch





D4

Locate a vacant medium or large sized grommet for the power switch wire



D5



Inside electrical box, uncover bottom and left side Panduits

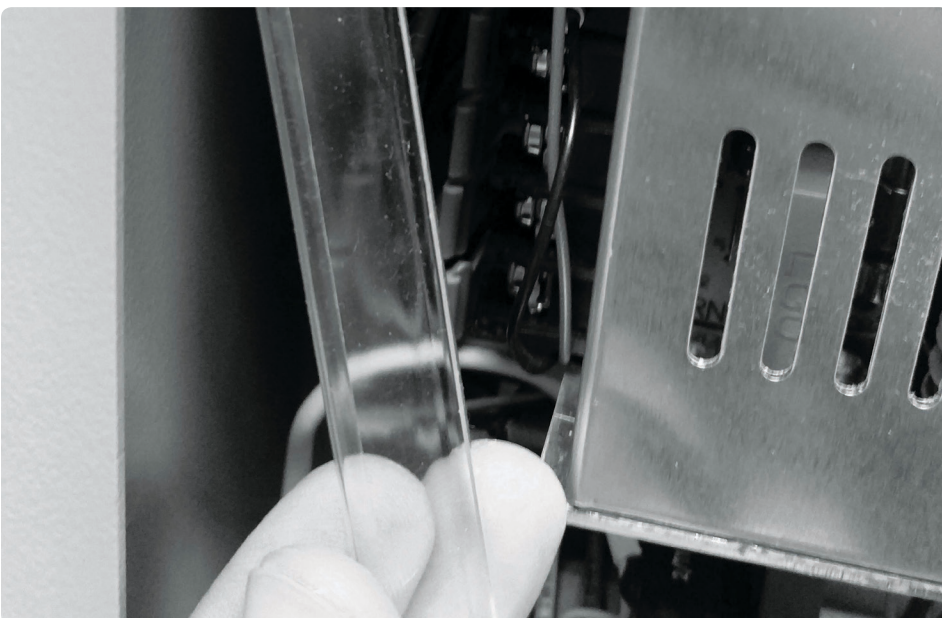

D6



Lift the terminal cover from the power supply

D7

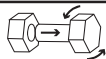

Use a right angle screwdriver to unscrew the lowest terminal and remove the spade terminal wire for the power switch



D8



Disconnected spade terminal

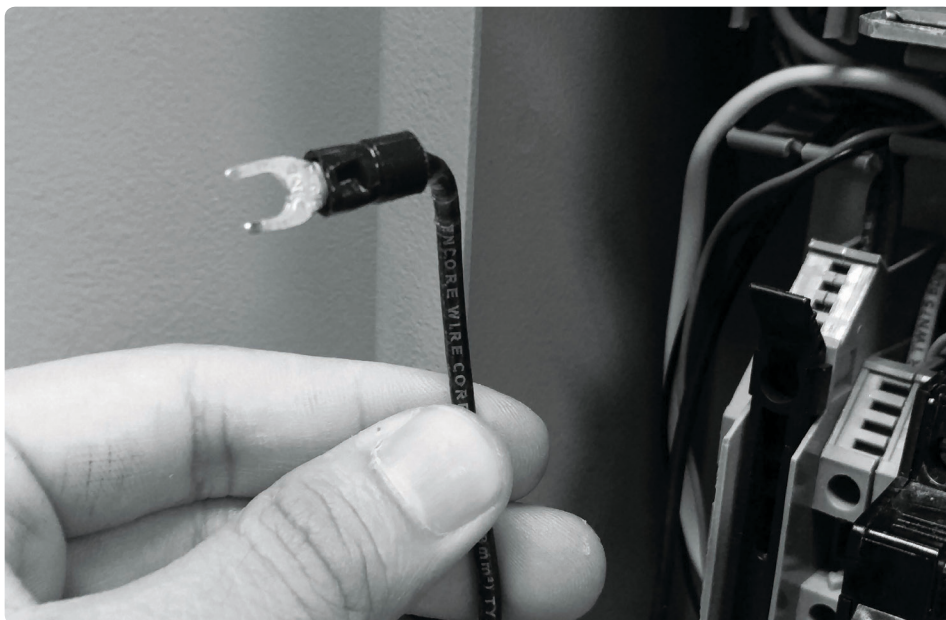

D9

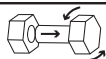

Unscrew the fuse block terminal and remove the bare end wire for the power switch

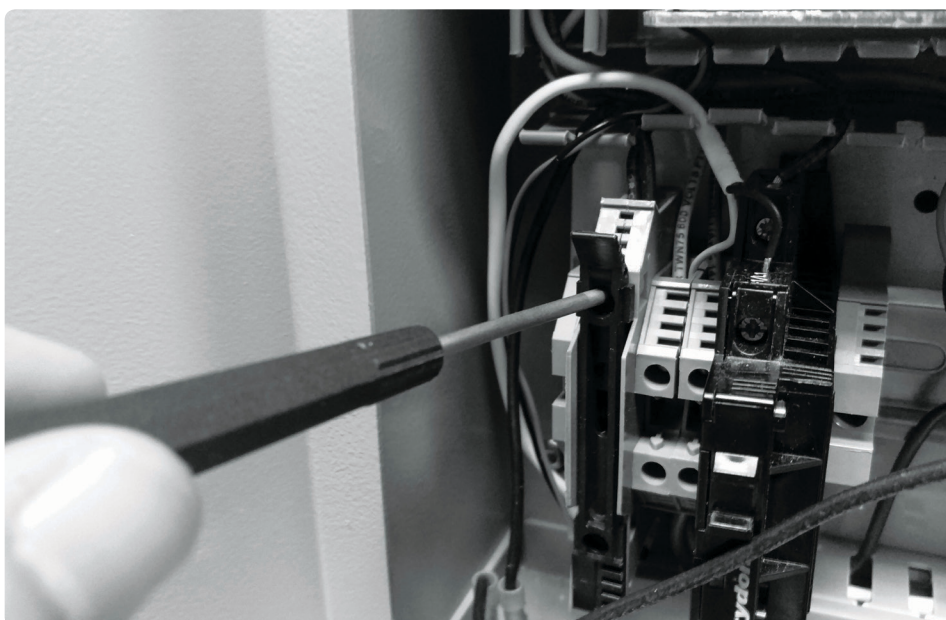

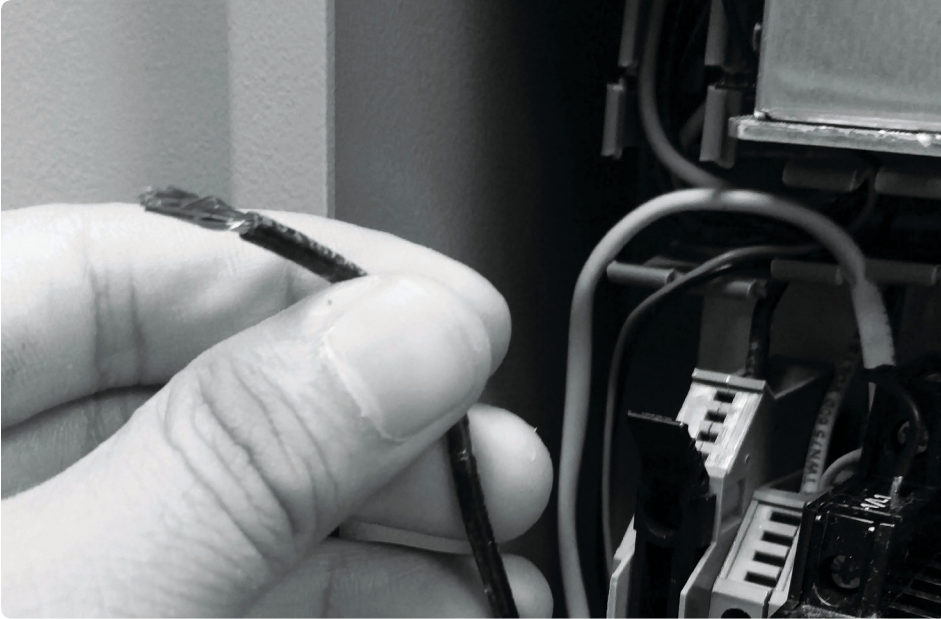

D10

Disconnected bare end from fuse block



D11



Disconnect both wires from existing power switch and remove them

It may be helpful to use needle nose pliers

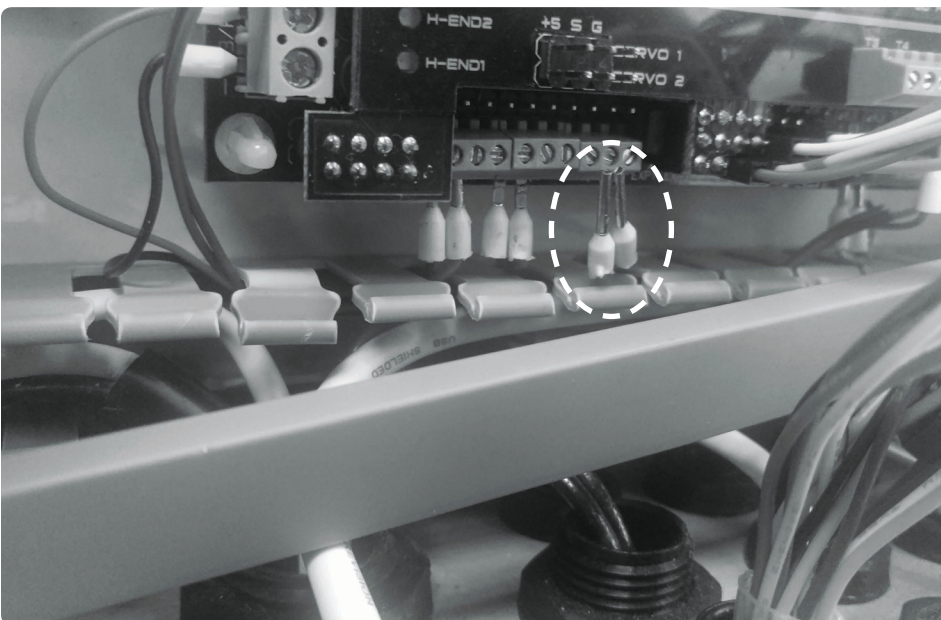

D12

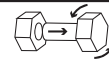

Unscrew terminals for Z limit switch and remove old wires

D13



Remove wires by routing out of grommet and route new Z limit switch through

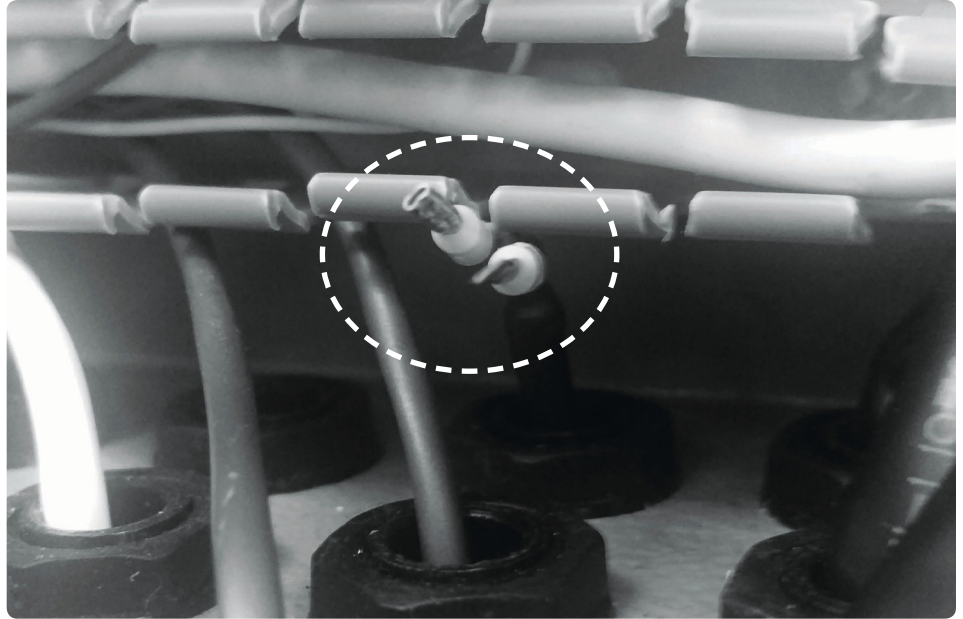

D14

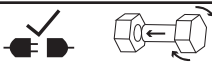

Connect and screw terminals to connect Z limit switch wires



D15



Route new power switch wire through grommet and into electrical box

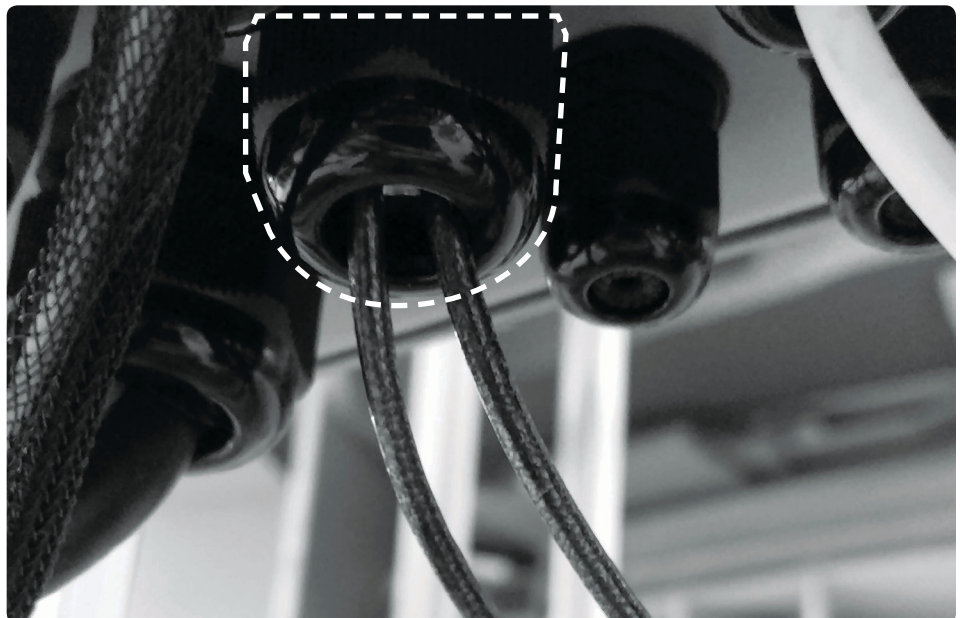

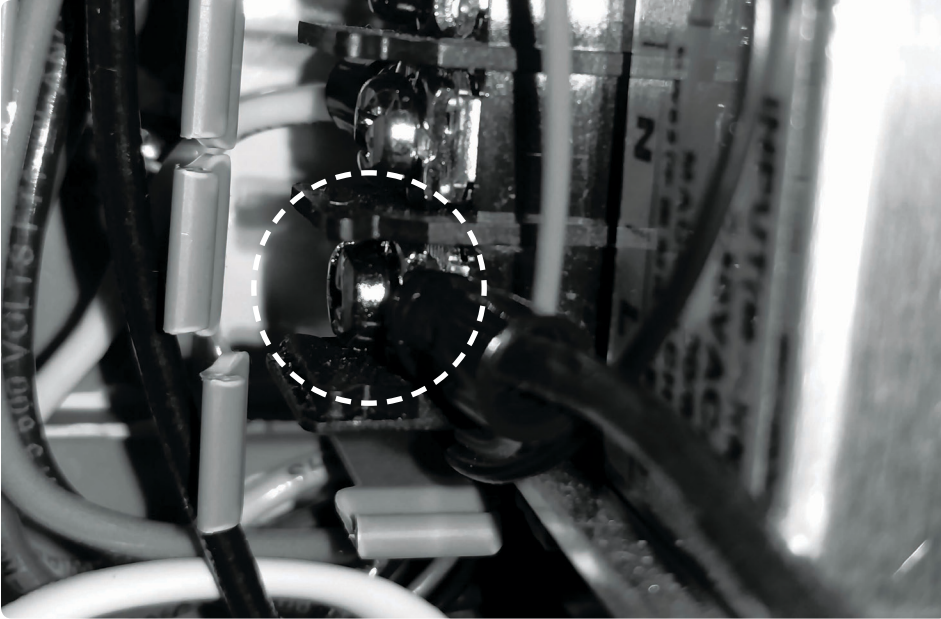

D16



Connect and screw spade terminal wire to power supply

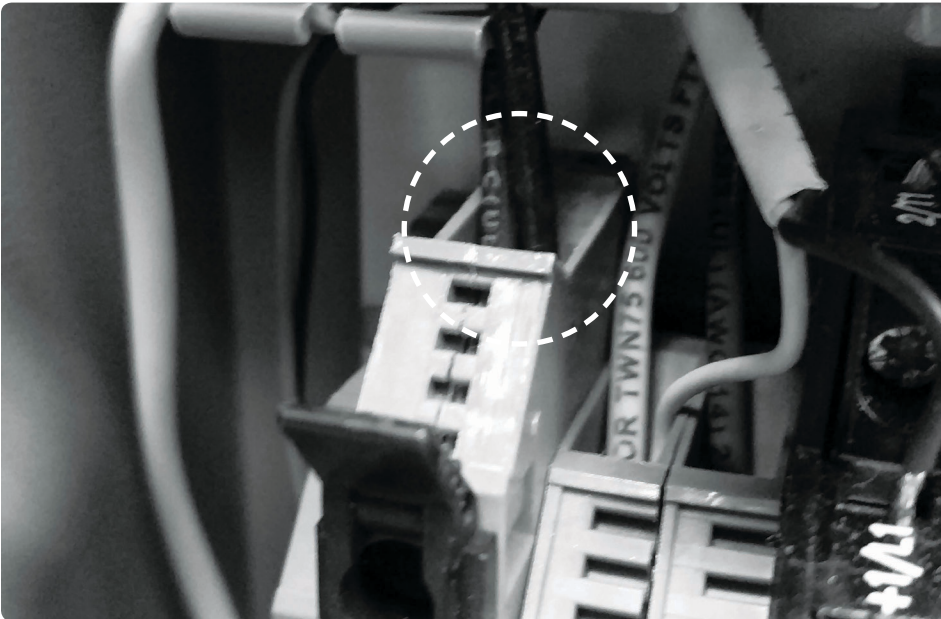

D17



Connect and screw bare end wire into fuse block

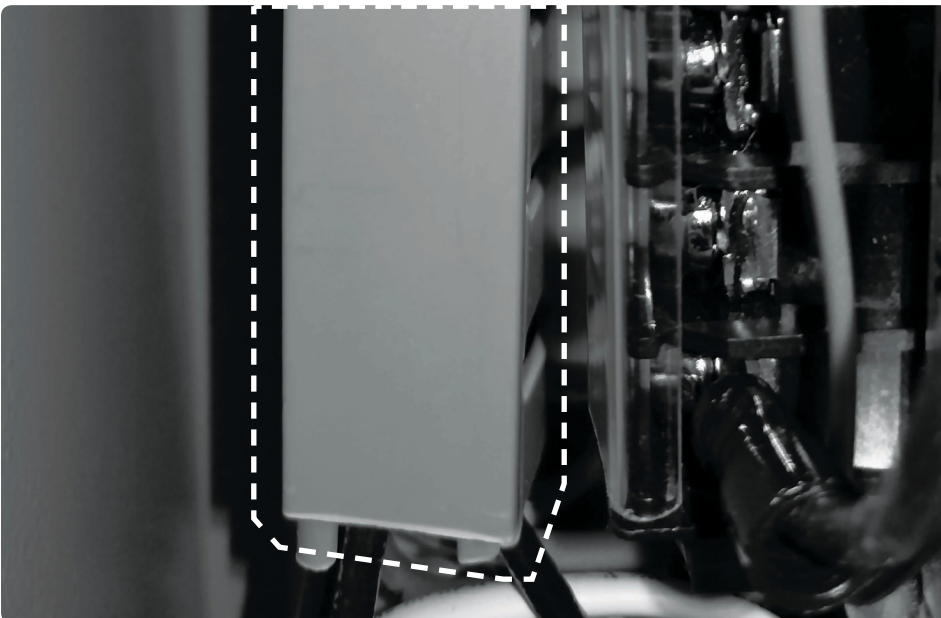

D18

Organize wires into surrounding Panduits and cover

D19

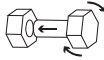

Tighten grommets for Z
limit switch and power
switch



D20

Close electrical box and
test Gigabot for power
switch and Z limit switch
functionality



DOUBLE-CHECK YOUR WORK :

Please look over your completed kit and make sure everything has been assembled correctly. If you have further questions, please refer to the video instructions (search “re3D Tech” on YouTube and find “Power and Z Limit Switch Relocation” video) or contact us through the references listed in the conclusion.

NOW IS A GOOD STOPPING POINT...

Acquire beverage of
your choice

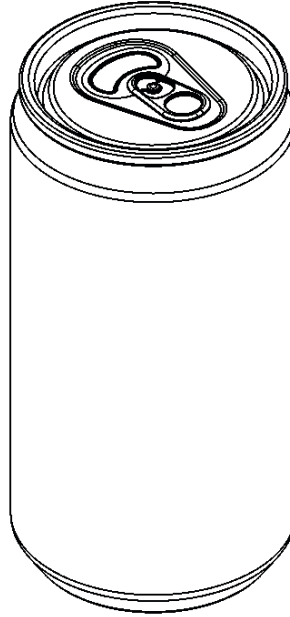

Actuate pull tab

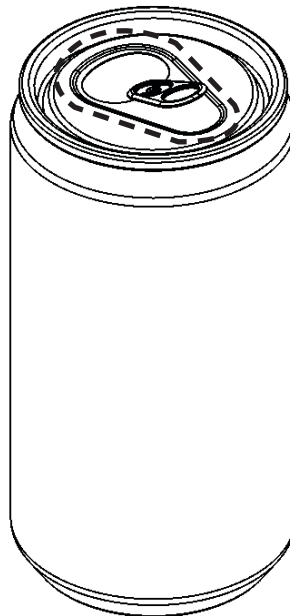

Consume

CONCLUSION

CONGRATULATIONS! YOU HAVE NOW COMPLETED THE POWER AND Z LIMIT SWITCH RETROFIT ON YOUR GIGABOT®.

We are confident that you will find this upgrade very helpful in your every day use of the Gigabot®, but please do not hesitate to contact us for any further issues or questions. Feedback on assembly instructions, support, and other aspects of your experience are welcome. Reach out to us at:

WIKI : wiki.re3d.org

EMAIL : support@re3d.org

PHONE : 512-730-0033

Happy printing!

THINK BIG, PRINT HUGE!

From the re:3D Inc.® team

REFERENCES & DOCUMENTS

**GIGABOT® PARTS KIT
OPENING GUIDE :**

http://wiki.re3d.org/images/1/13/Parts_Kit_Box_Opening_Guide_v1.pdf

**POWER AND Z LIMIT
SWITCH RELOCATION
MANUAL PDF :**

<http://wiki.re3d.org>

**re:3D Inc.® YouTube
CHANNEL :**

<https://www.youtube.com/user/GigaBot3D>

**GIGABOT® AZTEEG
WIRING DIAGRAM :**

<http://wiki.re3d.org>



re:3D Inc.® | re3d.org | support@re3d.org